

Apo-Nikkor Lenses

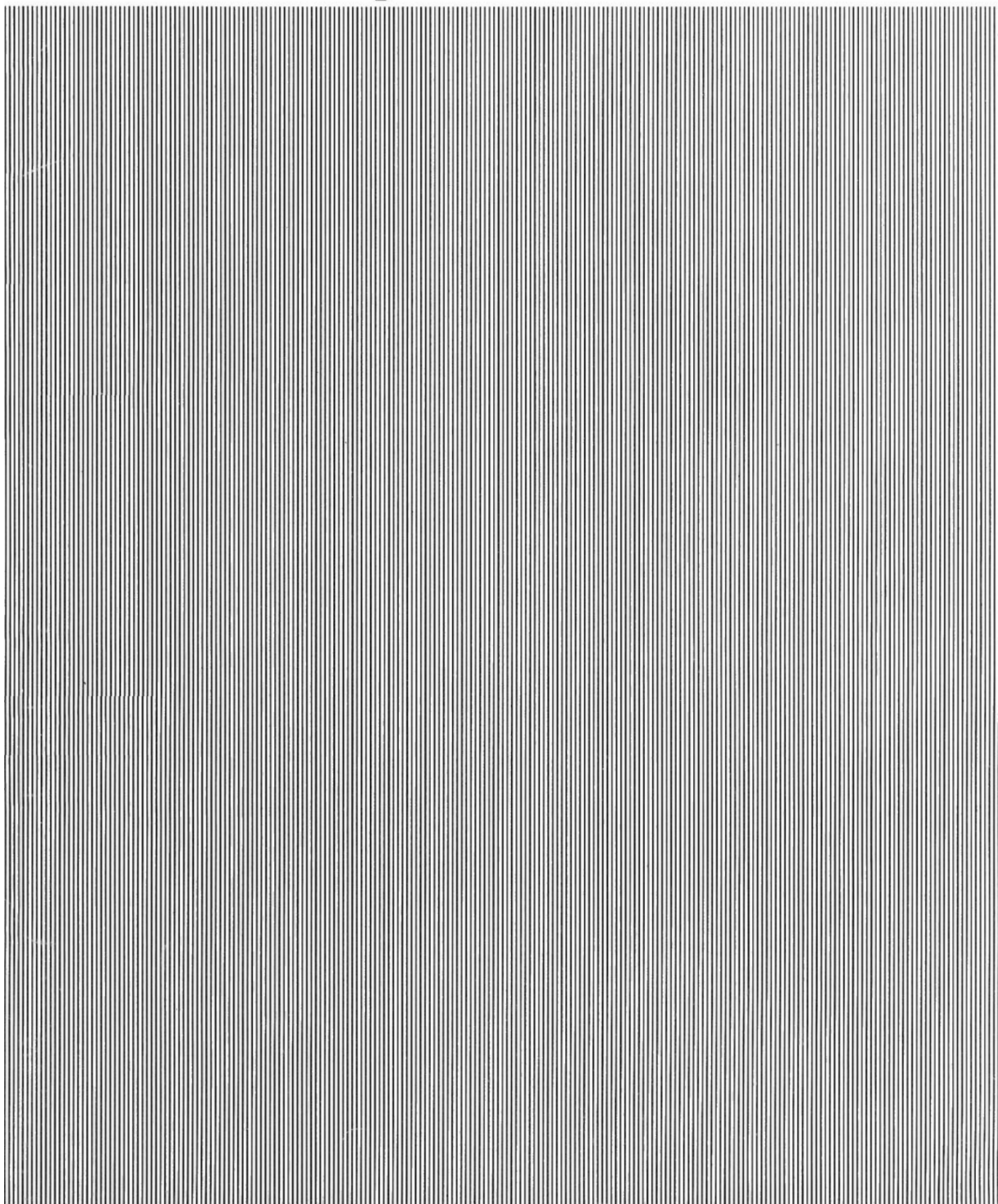

APO-NIKKOR LENSES

Apo-Nikkor lenses are Nippon Kogaku's line of apochromatic lenses specially designed for use in photoengraving applications requiring the most critical reproduction of originals. As the chromatic aberration in these lenses is strictly corrected, there is almost no visible image displacement at the image plane, nor difference in the image sizes of consecutive exposures during color separating.

Apo-Nikkor lenses are built taking into full consideration the special requirements of photoengraving lenses. For example, Apo-Nikkors feature a symmetrical construction for maximum performance at a reproduction ratio of 1:1, the standard for most photoengraving situations. Apochromatic correction enables coincidence of focus for red, green and blue, as necessitated by the use of these primary colors for color separations. A wealth of other features, as mentioned in the following section, is included to enhance the overall performance and desirability of using Apo-Nikkor lenses for all photoengraving and color separation processes. Apo-Nikkors are available in twelve different focal lengths for a wide range of applications and format size requirements. Table 1 details the basic lens characteristics.

LENS	MAX. APERTURE	IMAGE AREA (diagonal)
180mm	f/9	300mm (11-1/8")
240mm	f/9	410mm (16-1/8")
305mm	f/9	520mm (20-1/2")
360mm	f/9	600mm (23-5/8")
420mm	f/9	710mm (28")
455mm	f/9	770mm (30-1/4")
480mm	f/9	820mm (32-1/4")
610mm	f/9	1,030mm (40-1/2")
760mm	f/11	1,170mm (46")
890mm	f/11	1,360mm (53-1/2")
1210mm	f/12.5	1,750mm (68-11/12")
1780mm	f/14	2,310mm (91")

Table 1 Apo-Nikkor Lenses

Apo-Nikkor Lens Features

1) Reproduction Ratio

In photoengraving work, the original is usually placed at a close distance to the lens, generally corresponding to a reproduction ratio of 1:1. Accordingly, Apo-Nikkor lenses are symmetrical in construction to give maximum performance at the 1:1 ratio. As these lenses are relatively slow, and are designed so that positions of the principal points and the entrance/exit pupils are almost coincident, aberrations are fully corrected for the best performance under typical using situations.

2) Resolving Power

The need to faithfully reproduce delicate and complicated type faces has dictated the high resolving power requirements used in designing Apo-Nikkor lenses. Apo-Nikkors offer exceptional resolution for the most demanding photoengraving applications.

3) Maximum Aperture Performance

Although Apo-Nikkor lenses are rather slow (i.e., have a small maximum aperture ratio), their high level of aberration correction ensures high image sharpness at the maximum aperture setting. Thus, focusing may be performed at the fully open position (for maximum brightness) without fear of image shift as the diaphragm is stopped-down to the shooting aperture. Generally speaking, the lens can be used as wide open as only 2-stops below the maximum setting, with uniform brightness free of vignetting; in fact, it is recommended that the lenses be used in this way at all times, unless special requirements of the situation dictate further closing.

4) Chromatic Aberration Correction

The name Apo-Nikkor means a Nikkor lens employing apochromatic correction. All of these lenses are strictly corrected for the wavelengths of red, green and blue, as well as highly corrected for all others in the 380 ~ 750nm wavelength range. Therefore, even when more than three-color separation is being performed, each image exhibits the same uniform sharpness and image size; all colors match perfectly for the sharpest reproduction.

5) Correction for Near-Ultraviolet Range

There is considerable difference between the spectral sensitivity of the human eye (favoring energy from 400nm to 700nm) and that of photosensitive materials (highly responsive to ultraviolet energy from 350nm to 450nm). To ensure that focusing, as performed by the naked eye, is accurate for the sensitivity range of commonly used materials, Apo-Nikkor lenses are corrected for chromatic aberration to 380nm and feature optical glass carefully selected for minimum ultraviolet absorption.

6) Uniformity of Image Quality

In order to maintain uniform and faithful reproduction of the entire area of a relatively large original, Apo-Nikkor lenses are designed for light transmission from edge to edge. There is almost no qualitative difference between the central and peripheral areas of the image.

7) Symmetrical Construction

As the optical construction of Apo-Nikkor lenses is fully symmetrical in relationship to the positioning of the built-in iris diaphragm (or diaphragm plate), lens distortion at a reproduction ratio of 1:1 is theoretically 0%. This characteristic enhances the desirability of using Apo-Nikkor for critical reproduction of complex patterns, etc.

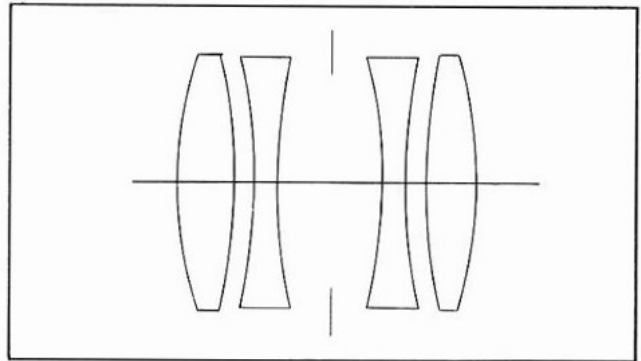

Fig. 1

Lens Barrel Construction

The lens barrels of Apo-Nikkors have been designed for maximum ease of handling during photoengraving operations. Each barrel is provided with a front mounting thread to accept connection of a screw-mounting hinged lens cap, a right-angle prism, a roof prism, or a right-angle mirror; the front mount size matches that of the rear mount to provide for interchangeable mounting. Each lens is provided with a slot for insertion of slip-in type diaphragm plates with individually prepared apertures (e.g., as for special effects), or gelatine filter holders. To provide for remote control of the aperture setting, the diaphragm control ring is constructed with a wide lip and has holes for mounting a remote control ring; further enhancing operation here is the use of equidistant spacing (in increments of 1/3-stop) of graduations on the diaphragm ring.



4

Apo-Nikkor	Fig.	Dimensions (mm)																		
		A	B	C	D	E	F	G	H	I	J	K	L	M	N	T	U	V	W	X
180mm/9	2	74	67	55	53 x 0.75	50	44 x 0.5	64	55	45.6	5	2.5	6.5	4	24.5	2.8	5.5	61	—	—
	3						47 x 0.5	78					4	2.5				64	72	4.5
240mm/9	2	74	67	55	53 x 0.75	50	47 x 0.5	64	55	45.6	5	2.5	6.5	4	24.5	2.8	5.5	61	—	—
	3						78	4					2.5	64				72	4.5	
305mm/9	2	98	88	74.5	72 x 1	70	64 x 0.75	86	74.5	56.1	6.5	2.5	8.5	4	34.5	4.3	6	82	—	—
	3						67 x 0.75	100					5	2.5				86	94	5.5
360mm/9	2	98	88	74.5	72 x 1	70	67 x 0.75	86	74.5	56.1	6.5	2.5	8.5	4	34.5	4.3	6	82	—	—
	3						100	5					2.5	86				94	5.5	
420mm/9	2	121	109	94	90 x 1	88	86 x 0.75	105	94	71.1	7.5	3	12	7	45	4.3	6	101	—	—
	3						123	8					3	107				117	8	
455mm/9	3	121	109	94	90 x 1	88	86 x 0.75	123	94	71.1	7.5	3	8	3	45	4.3	6	107	117	8
	2						105	12					7	101				—	—	
480mm/9	2	121	109	94	90 x 1	88	86 x 0.75	105	94	71.1	7.5	3	12	7	45	4.3	6	101	—	—
	3						123	8					3	107				117	8	
610mm/9	2	145	131	114	110 x 1	108	105 x 0.75	127	114	79.9	12.7	4	12.8	7	49.1	4.3	8	123	—	—
	3						146	9.3					3	132				140	8	
760mm/11	3	145	131	114	110 x 1	108	105 x 0.75	146	114	79.9	9.7	4	9.3	3	49.1	4.3	8	132	140	8
890mm/11	2	208	192	168	162 x 1.5	159.5	153 x 1	186	166	117	13	5	27.5	9	80	5.3	11	178	—	—
1210mm/12.5	2	208	192	168	162 x 1.5	159.5	153 x 1	186	166	117	13	5	27.5	9	80	5.3	11	178	—	—
1780mm/14	4	260	240	220	213 x 1.5	210	153 x 1	235	215	179.5	7.5	5	51.5	11	140	5.3	12.5	230	—	—

Table 2 Lens Dimensions (with reference figures)

Fig. 2

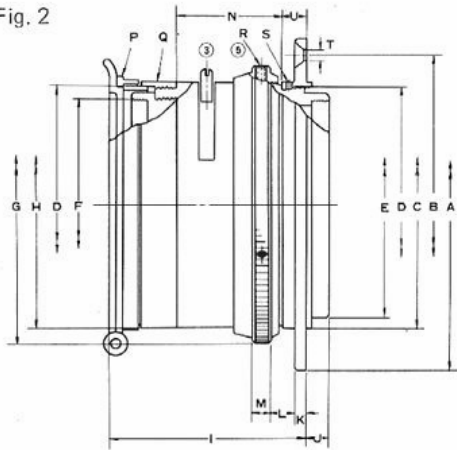

Fig. 4

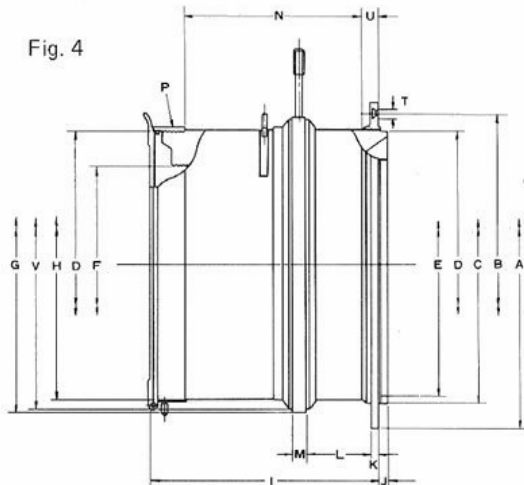
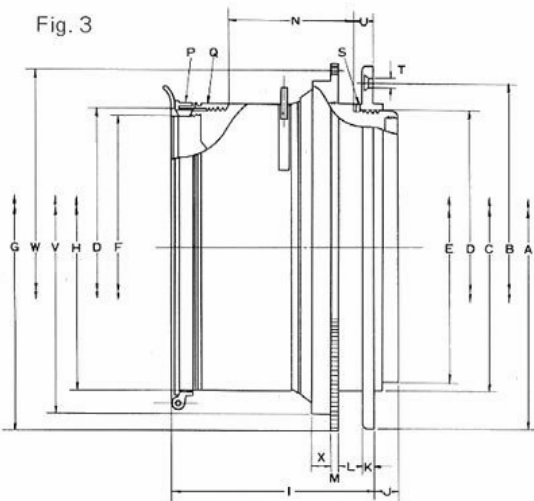

Fig. 3



Notes:

- 1) Figure 2 illustrates the standard lens configuration, while Figure 3 depicts lenses equipped with the MIDC ring.
- 2) Figure 4 is applicable for the 1780mm lens only.

Additional Applications

In addition to use in photoengraving/color separation processes, Apo-Nikkor lenses are suitable for use in other photographic applications. With their superb optical performance, these lenses are suitable for use as general photographic lenses mounted on view cameras or studio cameras. Also, the exceptional aberration correction of these lenses enables their use as enlarging lenses for either black-and-white or color, and as reproduction lenses in electrostatic photography, micro-photography and industrial photography applications.

Choosing the Correct Focal Length

Long focal length lenses appear initially to be advantageous as they have a large image circle and can cover a wide range of original sizes. However, the longer the focal length, the greater the aberrations (in particular, chromatic aberration is almost directly proportional to focal length) and the longer the overall working distance (thus requiring a large camera). Accordingly, long focal length lenses are not recommended for use in situation where a shorter length lens would perform the job satisfactorily; in short, the shorter the focal length, the better the quality, as long as the lens selected covers the necessary picture field.

In determining the most suitable focal length to use, three factors—image size, original size and reproduction ratio—must be decided, with the knowledge of any two factors generally determining the third. This is readily understandable when we realize that reproduction ratio is equal to the diagonal of the image divided by the diagonal of the original. The following procedure should be followed to determine the focal length of the lens to be used.

- 1) Calculate the diagonal of the original (or if enlarging, that of the image) using the graph in Figure 6. Once determined, check the values given in Table 3 and choose a lens which covers a slightly longer diagonal than that obtained. Among lenses covering a bigger diagonal than required, the lens with the shortest focal length should be selected.

Lens	Ratio/Image Size					
	1 : 1	1 : 2	1 : 3	1 : 4	1 : 5	1 : 10
180mm/ 9	30cm	23cm	20cm	19cm	18cm	17cm
240mm/ 9	41	31	27	26	25	23
305mm/ 9	52	39	35	33	31	29
360mm/ 9	60	45	40	38	36	33
420mm/ 9	71	53	47	44	43	39
455mm/ 9	77	58	51	48	46	42
480mm/ 9	82	62	55	51	49	45
610mm/ 9	103	77	69	64	62	57
760mm/11	117	88	78	73	70	64
890mm/11	136	102	91	85	82	75
1210mm/12.5	175	131	117	109	105	96
1780mm/14	231	173	154	144	139	127

Table 3 Diagonal of Effective Image

- 2) Having selected the shortest possible focal length lens from Table 3, overall working distance should be checked to ensure that the camera length or bellows extension is sufficiently long enough to meet the operating requirements. Use values detailed in Table 3.

The overall working distance (which dictates the length of the camera) is given by the following:

$$A = (2 + M + 1/M) \times (f) \dots \dots \dots (1)$$

where

- A = overall working distance
- M = reproduction ratio
- f = focal length of the lens

The extension of the bellows represents the distance from the image to the lens center, and is given by the followings:

$$b = (1 + M) \times (f) \dots \dots \dots (2)$$

where

- b = length of bellows extension
- M = reproduction ratio
- f = focal length of the lens

When the values calculated from equations (1) or (2) are smaller than the length of the equipment to be used, the lens selected is considered suitable. Working distance values at the main reproduction ratio are also shown in Table 4.

The previous two equations are also applicable when designing a new camera. However, the results obtained are only approximate. Thus, when exact values are required, use the precise optical data on the inspection card included with the lens.

Figure 5 shows the optical dimensions taking the focal points F and F' as basic points. The precise total length will be

$$A' = a + b + HH'$$

That is, the precise length will be obtained by adding the distance between the principal points (HH') to the value of A obtained using equation (1) with the actual focal length of the lens as entered on the inspection card.

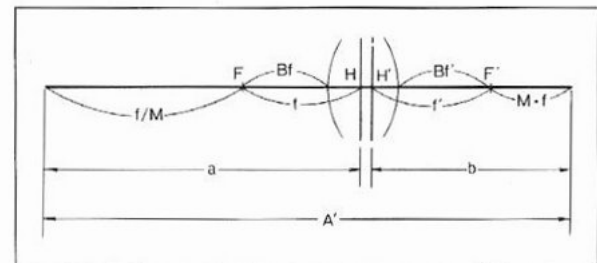

Fig. 5

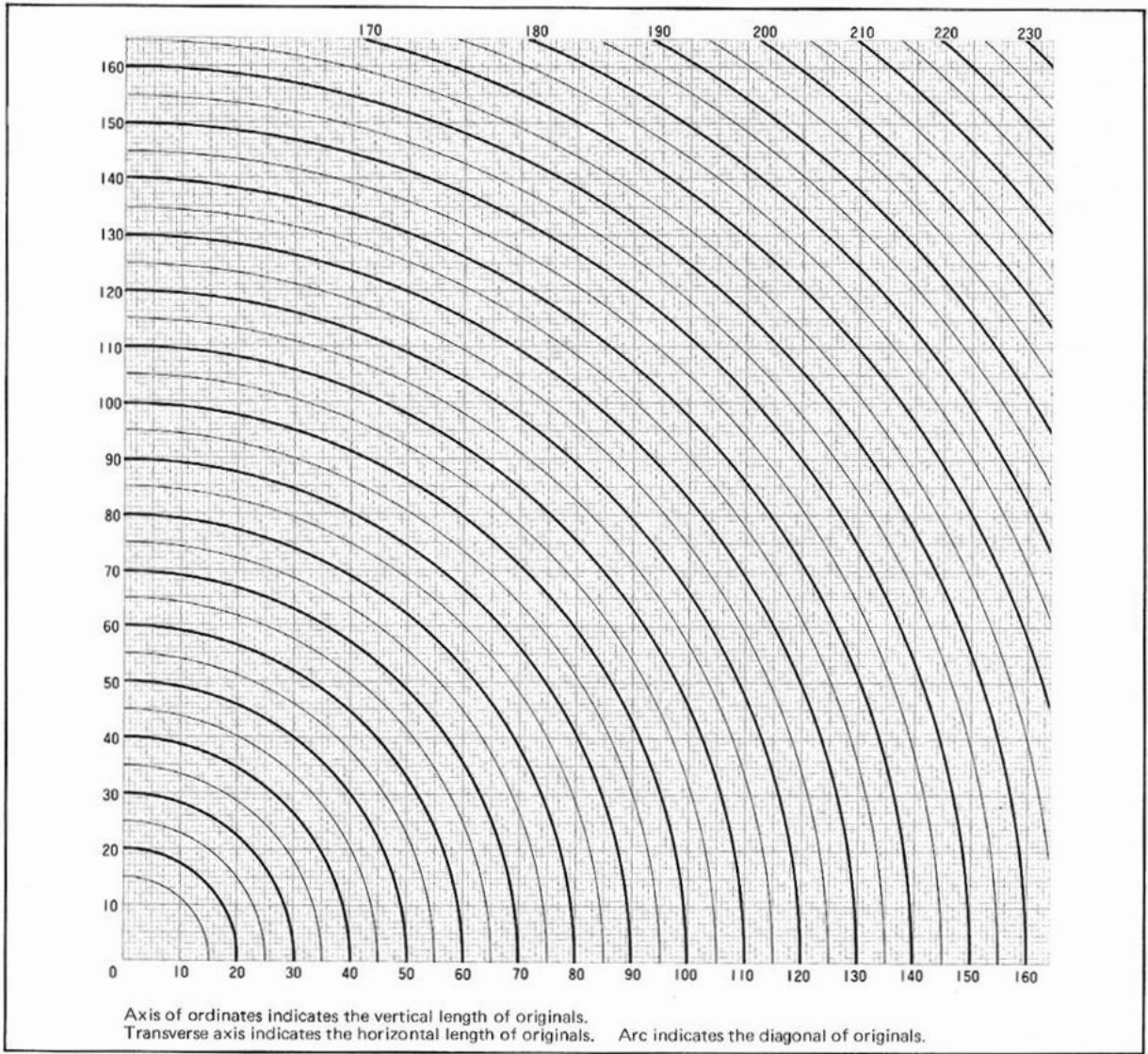

Fig. 6 Diagonal Calculation Graph

Example

What is the best focal length when the original is 1m x 1m and the reproduction ratio is 1:2?

- 1) Using Figure 1, we find that the diagonal of the original is 1,400mm (1.4m).
- 2) As the prescribed reproduction ratio is 1:2, the diagonal of the image will be 700mm (0.7m).
- 3) Checking Table 3, we find that the lens which covers a diagonal of 700mm at a reproduction ratio of 1:2 is the Apo-Nikkor 610mm f/9 lens.
- 4) With the 610mm lens, the overall working distance will be
 $A = (2 + 2 + 1/2) \times 610\text{mm} = 2,745\text{mm}$

Thus, the camera to be used should be capable of providing at least 2,745mm overall working distance.

Apo-Nikkor Lens	Reproduction Ratio/Working Distances (cm)																	
	1 : 1			1 : 2			1 : 3			1 : 4			1 : 5			1 : 10		
	a	b	A	a	b	A	a	b	A	a	b	A	a	b	A	a	b	A
180mm/ 9	36	36	72	54	27	81	72	24	96	90	23	113	108	22	130	198	20	218
240mm/ 9	48	48	96	72	36	108	96	32	128	120	30	150	144	29	173	264	26	290
305mm/ 9	61	61	122	92	46	138	122	41	163	153	38	191	183	37	220	336	34	370
360mm/ 9	71	71	142	107	53	160	142	47	189	178	45	223	214	43	257	392	39	431
420mm/ 9	84	84	168	126	63	189	168	56	224	210	52	262	251	50	301	461	46	507
455mm/ 9	91	91	182	137	68	205	182	61	243	228	57	285	273	55	328	501	50	551
480mm/ 9	97	97	194	145	72	217	193	64	257	242	60	302	290	58	348	531	53	584
610mm/ 9	122	122	244	183	92	275	244	81	325	305	76	381	366	73	439	671	67	738
760mm/11	152	152	304	229	114	343	305	102	407	381	95	476	457	91	548	838	84	922
890mm/11	178	178	356	267	133	400	356	119	475	445	111	556	533	107	640	978	98	1076
1210mm/12.5	241	241	482	362	181	543	483	161	644	603	151	754	724	145	869	1327	133	1460
1780mm/14	356	356	712	533	267	800	711	237	948	889	222	1111	1067	213	1280	1956	196	2152

Table 4 Working Distances at Various Reproduction Ratios

Mounting on the Process Camera

All Apo-Nikkor lenses are fitted with a mounting flange to provide sure, sturdy connection to the process camera in use. The following is the procedure for attaching the flange to the camera.

- 1) Mark the mounting flange (a grease pencil should be satisfactory) to indicate the location of the slot for the slip-in diaphragm plates.
- 2) Loosen the setscrew securing the mounting flange in position, and remove the flange from the lens.
- 3) Attach the mounting flange to the front plate of the camera via the mounting hardware provided. When positioning the flange, make sure that the previously marked point (see step 1) is to the top, thus placing the slot for the diaphragm plates facing upward.
- 4) Screw the lens into the flange (now mounted on the camera), and secure with the setscrew.

Screw-mounted Hinged Lens Cap

All Apo-Nikkor lenses are provided with two lens caps, both suitable for mounting on either end of the lens. With normal lens mounting (i.e., the lens attached to the flange via the rear mount), the slip-on cap is attached to the rear of the lens, with the screw-mounted hinged lens cap attached to the front mount.

To remove the screw-mounted lens cap from the lens barrel, turn the mounting ring counterclockwise until free. For the 1780mm lens, the mounting ring is secured in position with a setscrew; thus, to disconnect the cap on this lens, first loosen the screw and then turn the ring until free.

An additional feature of the screw-mounted hinged lens cap is the ability to open the cap in any direction on the lens axis. To shift the cap to the desired position for opening, grasp the mounting ring firmly (to prevent the ring from turning on the lens mount) and rotate the front piece until it opens to the desired direction. For the 1780mm lens, the front piece and mounting ring do not turn independently; thus, to adjust this lens cap for the desired opening direction, rotate the front piece and ring from the fully screw-on position until the desired position is reached, and then secure with the setscrew.

Built-in Iris Diaphragm

All Apo-Nikkor lenses are fitted with a built-in iris diaphragm having a continuously variable aperture, adjusted via the outer ring provided. The ring is provided with an aperture scale graduated in 1/3-stop increments across the full range. A change to the third lower setting results in a 50% reduction in brightness (the diameter is reduced by $1/\sqrt{2}$), while a change to the third higher setting results in a doubling of the brightness. Of course, when adjusting the aperture setting, corresponding changes in the exposure time will be necessary. (See Figure 3 for effective apertures.)

Apo-Nikkor	Iris Diaphragm			
	Aperture range	Dia. of opening (mm)	Range of equidistant marking	Rotating angle
180mm/ 9	1 : 9~128	18.2~1.3	1 : 9~90	133° 30'
240mm/ 9	1 : 9~128	24.2~1.7	1 : 9~90	133° 30'
305mm/ 9	1 : 9~128	30.1~2.1	1 : 9~90	133° 30'
360mm/ 9	1 : 9~128	36.0~2.5	1 : 9~90	133° 30'
420mm/ 9	1 : 9~128	42.3~3.0	1 : 9~90	133° 30'
455mm/ 9	1 : 9~128	46.3~3.3	1 : 9~90	133° 30'
480mm/ 9	1 : 9~128	48.8~3.4	1 : 9~90	133° 30'
610mm/ 9	1 : 9~128	61.0~4.2	1 : 9~90	133° 30'
760mm/11	1 : 11~128	64.0~5.4	1 : 11~90	121° 30'
890mm/11	1 : 11~128	74.4~6.4	1 : 11~90	121° 30'
1210mm/12.5	1 : 12.5~128	89.4~8.7	1 : 12.5~90	115° 30'
1780mm/14	1 : 14~128	117.0~12.8	1 : 14~128	114°

Table 5 Iris Diaphragm Specifications

Slip-in Diaphragm Plates

The lens barrels of Apo-Nikkor lenses are fitted with a slot to permit the use of (Waterhouse stop type) diaphragm plates of slip-in design. These plates (five plates each are supplied with the 890mm, 1210mm, and 1780mm lenses) can be tilted within the slot in accordance with the requirements of the using situation. These plates may be used to create specially shaped apertures for specific shooting requirements. For special effects, widen and modify the shape of the hole until the desired shape is achieved; Table 6 shows the relationship between the dimensions of a square hole and the f-number achieved. When no plate is installed in the lens, the slot should be closed (a lever is provided for this purpose) to prevent the entry of contaminants into the interior of the lens.

Apo-Nikkor	Diameter of central opening of Waterhouse plate (mm)	Side length of square opening on Waterhouse plate (mm)								
		F11	F16	F22	F32	F45	F64	F90	F128	
180mm/ 9	1.3	12.8	9.0	6.4	4.5	3.2	2.3	1.6	—	
240mm/ 9	1.3	17.2	12.0	8.6	6.0	4.3	3.0	2.1	1.5	
305mm/ 9	2.1	21.3	14.9	10.7	7.5	5.3	3.7	2.7	—	
360mm/ 9	2.1	25.3	18.0	12.7	8.9	6.4	4.5	3.2	2.2	
420mm/ 9	3.0	29.9	21.1	14.9	10.5	7.4	5.2	3.7	—	
455mm/ 9	3.0	32.1	23.0	16.3	11.5	8.1	5.8	4.1	2.9	
480mm/ 9	3.0	34.4	24.4	17.2	12.1	8.5	6.1	4.3	3.0	
610mm/ 9	4.2	43.0	30.0	21.3	15.1	10.6	7.5	5.3	—	
760mm/11	4.2	—	38.5	27.2	19.2	13.6	9.7	6.8	4.8	
890mm/11	6.0	—	45.4	32.1	22.7	16.0	11.3	8.0	—	
1210mm/12.5	6.0	—	61.8	43.8	30.9	21.9	15.5	10.9	7.7	
1780mm/14	12.8	—	—	64.1	45.4	33.1	22.7	16.0	—	

Table 6 Hole Size/Aperture Relationships

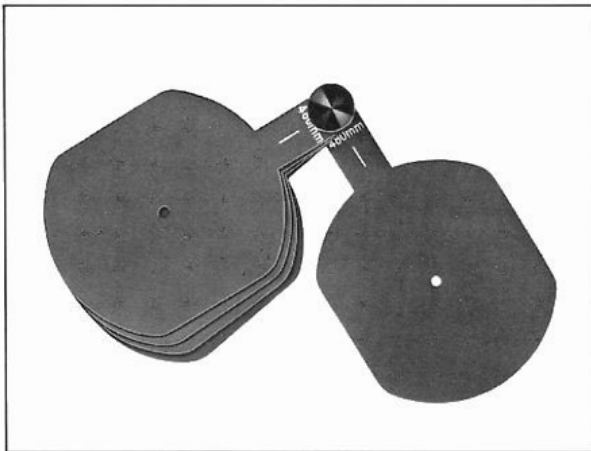

Slip-in Filter Holders

Holders for gelatine filters are available as accessories for Apo-Nikkor lenses. When a filter holder is inserted in the slot provided, the maximum aperture of some of the lenses is slightly reduced. These relationships are detailed in Table 7 below.

Apo-Nikkor	Maximum aperture ratio of filter holder
180mm/ 9	1 : 9
240mm/ 9	1 : 9
305mm/ 9	1 : 11
360mm/ 9	1 : 12.5
420mm/ 9	1 : 12.5
455mm/ 9	1 : 12.5
480mm/ 9	1 : 12.5
610mm/ 9	1 : 12.5
760mm/11	1 : 12.5
890mm/11	1 : 12.5
1210mm/12.5	1 : 12.5
1780mm/14	1 : 22

Table 7 Filter/Aperture Relationships

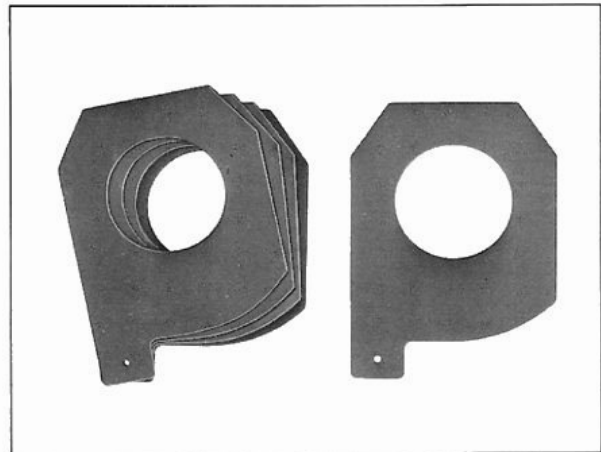

Magnification, f-number and Exposure Time

The f-number of a photographic lens generally indicates the brightness of the lens when the subject focused is at an infinite distance. As the subject is moved closer to the lens and its image becomes larger, however, the brightness decreases, even though the aperture size remains constant. This indicates that the practical f-number (effective f-number) varies with the reproduction ratio (magnification). The effective f-number is given by the following:

$$F_e = (1 + M) \times F ; M = \frac{\text{Size of Image}}{\text{Size of Original}}$$

where

F = f-number at infinity (∞) focus

F_e = f-number at M magnification

This means that the effective f-number becomes larger (and the effective aperture smaller) and the image darker under the same apertures as the magnification increases, thus necessitating an increase in the exposure time (or an increase in the size of the aperture) to obtain the same exposure. Tables 8 and 9 detail various factors concerning the relationship between the reproduction ratio and the effective f-number.

As Table 8 details, the effective f-number ratio will be 2 at 1:1 reproduction and 4 at a 3:1 ratio, when compared to the infinity (∞) focus condition; this means that the effective aperture is 2 stops darker at 1:1 and 4 stops darker at 3:1. If 1:1 is then used as a reference, image brightness will be four times higher at infinity and reduced to 1/4 at 3:1. By evaluating this data, it is easy to see that the exposure time must be changed by a factor inversely proportional to the brightness difference caused by the shift in the reproduction ratio. Remember, the exposure time is inversely proportional to the square of the effective f-number. Again, see Table 8 and Figure 3 (nomograph) for details.

Figure 3 shows the ratio of exposure time, with 1:1 magnification considered as standard. In order to keep the exposure time constant, the lens aperture must be adjusted in accordance with the effective f-number which varies with the changes in magnification. Table 9 and Figure 3 detail the aperture adjustments necessary to maintain equal image brightness without changing the exposure time.

Reproduction ratio (picture/image size: original size)	1 : ∞	1 : 10	1 : 5	1 : 4	1 : 3	1 : 2	1 : 1	2 : 1	3 : 1	4 : 1	5 : 1	10 : 1	M : 1
Effective f-number ratio	1	1.1	1.2	1.25	1.33	1.5	2	3	4	5	6	11	1 + M
Image plane illumination ratio	4	3.31	2.78	2.56	1.25	1.78	1	0.44	0.25	0.16	0.11	0.03	$\frac{4}{(1 + M)^2}$
Exposure time ratio	0.25	0.30	0.36	0.39	0.44	0.56	1	2.25	4	6.26	9	30.25	$\frac{(1 + M)^2}{4}$

Table 8 Effective f-number/Magnification Relationships

1 : ∞	1 : 10	1 : 5	1 : 4	1 : 3	1 : 2	1 : 1	2 : 1	3 : 1	4 : 1	5 : 1	10 : 1
18	16.4	15	14.4	13.5	12	9					
22	20	18.3	17.6	16.5	14.7	11					
32	29.1	26.7	25.6	24	21.3	16	10.7				
44	40	36.7	35.2	33	29.3	22	14.7	11			
64	58.2	53.3	51.2	48	42.7	32	21.3	16	12.8	10.7	
90	81.8	75	72	67.5	60	45	30	22.5	18	15	
					85.3	64	42.7	32	25.6	21.3	11.6
						90	60	45	36	29	16.4

Table 9 Magnification and f-number Variations with Constant Illumination

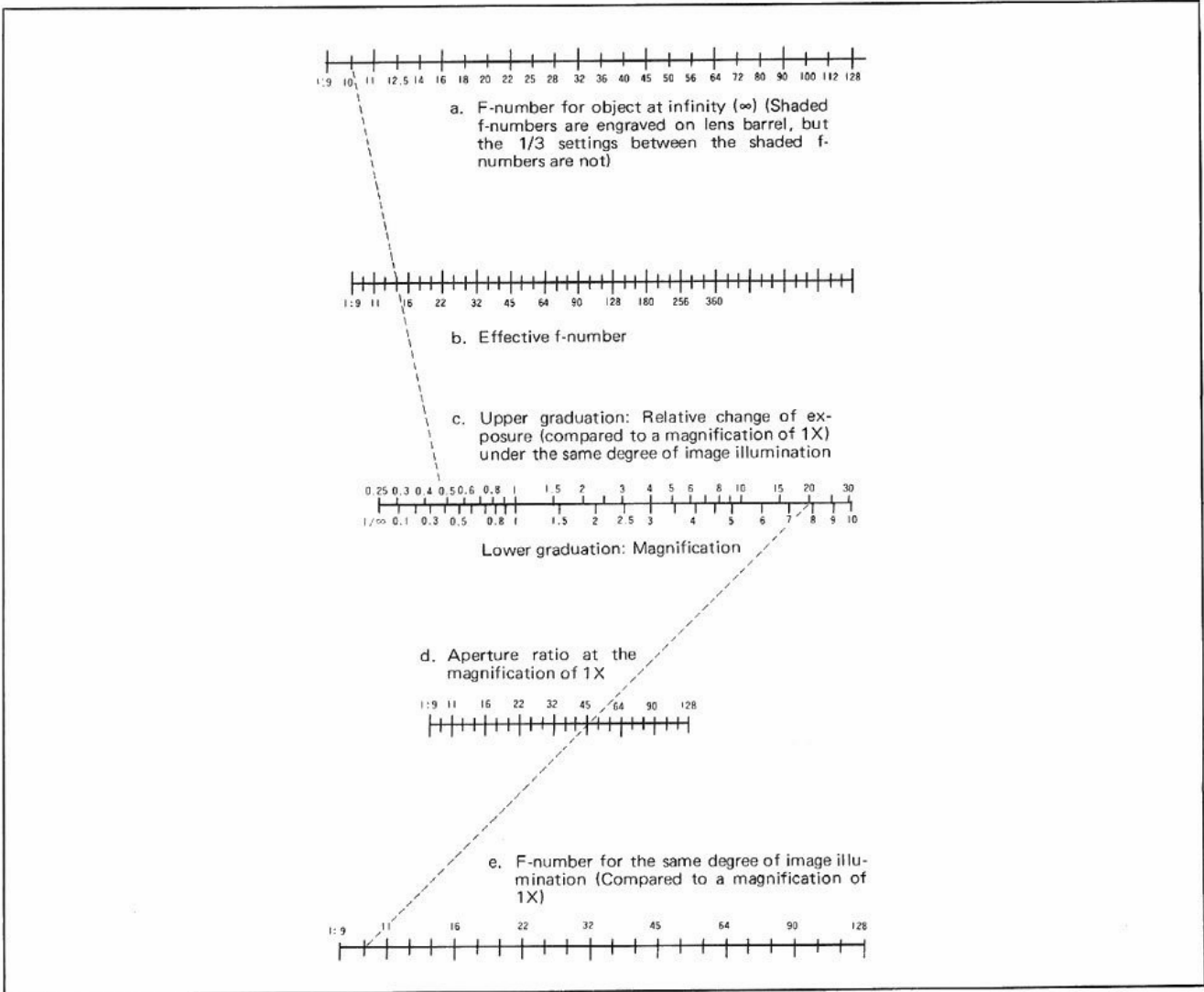

Fig. 7 Nomogram for Magnification, f-number and Illumination Calculations

Specifications

Apo-Nikkor	180mm f/9	240mm f/9	305mm f/9	360mm f/9	420mm f/9	455mm f/9
Focal length	180mm	240mm	305mm	356mm	419mm	455mm
Maximum aperture ratio	1 : 9					
Minimum f/stop	f/128					
Lens construction	4 elements in 4 groups					
Correction wavelength range	380 ~ 750nm (apochromatic)					
Standard magnification	1X					
Usable magnification range	1/10X ~ 10X					
Picture angle	46°					
Vignetting	0% (at f/16)					
Image size	300mmφ (at 1X)	410mmφ (at 1X)	520mmφ (at 1X)	600mmφ (at 1X)	710mmφ (at 1X)	770mmφ (at 1X)
Original size	300mmφ (at 1X)	410mmφ (at 1X)	520mmφ (at 1X)	600mmφ (at 1X)	710mmφ (at 1X)	770mmφ (at 1X)
Overall working distance	720mmφ (at 1X)	960mmφ (at 1X)	1,220mmφ (at 1X)	1,424mmφ (at 1X)	1,676mmφ (at 1X)	1,820mmφ (at 1X)
Weight	210g	220g	430g	470g	780g	810g

Apo-Nikkor	480mm f/9	610mm f/9	760mm f/11	890mm f/11*	1210mm f/12.5*	1780mm f/14*
Focal length	483mm	610mm	762mm	889mm	1,206.5mm	1,778mm
Maximum aperture ratio	1 : 9	1 : 9	1 : 11	1 : 11	1 : 12.5	1 : 14
Minimum f/stop	f/128					
Lens construction	4 elements in 4 groups					
Correction wavelength range	380 ~ 750nm (apochromatic)					
Standard magnification	1X					
Usable magnification range	1/10X ~ 10X					
Picture angle	46°	46°	42°	42°	40°	36°
Vignetting	0% (at f/16)					
Image size	820mmφ (at 1X)	1,030mmφ (at 1X)	1,170mmφ (at 1X)	1,360mmφ (at 1X)	1,750mmφ (at 1X)	2,310mmφ (at 1X)
Original size	820mmφ (at 1X)	1,030mmφ (at 1X)	1,170mmφ (at 1X)	1,360mmφ (at 1X)	1,750mmφ (at 1X)	2,310mmφ (at 1X)
Overall working distance	1,932mmφ (at 1X)	2,440mmφ (at 1X)	3,048mmφ (at 1X)	3,556mmφ (at 1X)	4,826mmφ (at 1X)	7,112mmφ (at 1X)
Weight	860g	1,450g	1,360g	3,600g	3,800g	6,430g

* Diaphragm plates and filter holders included as standard accessories

The equipment shown in this leaflet represents the latest available at the time of this printing. Designs and specifications are subject to change without notice.



NIPPON KOGAKU K.K.

Fuji Bldg., 2-3, 3-chome, Marunouchi,
Chiyoda-ku, Tokyo 100, Japan

☎ (03) 214-5311 Telex: J22601 (NIKON)

NIPPON KOGAKU (U.S.A.) INC.

623 Stewart Avenue, Garden City, New York 11530, U.S.A.

☎ (516) 248-4120 Telex: 096-7756 (NKUSA GRCY)

NIKON EUROPE B.V.

Freeport Bldg., Schiphol-Centrum, The Netherlands

☎ (020) 156633 Telex: 13328 (NIKON NL)

NIKON AG

Kaspar-Fenner-Strasse 6, 8700 Küsnacht/ZH, Switzerland

☎ (01) 909261 Telex: 53208 (NIKON CH)

NIKON G.m.b.H.

4000 Düsseldorf 30, Uerdinger Strasse 96-102, West Germany

☎ (0211) 451061 Telex: 8584019 (NIKO D)

Printed in Japan

8232-01 KEC 603-1/1