

Scanned by J.G.M. for personal use only  
Not for sale or commercial use

# OLYMPUS®

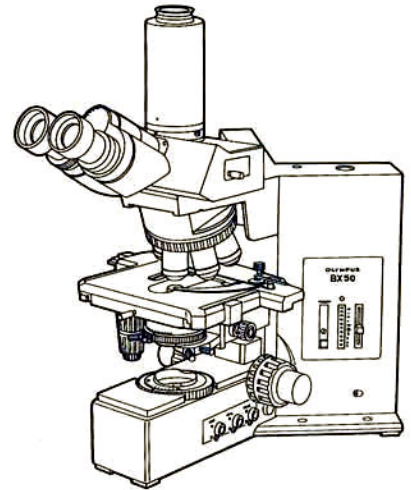

## INSTRUCTIONS

# BX50

## SYSTEM MICROSCOPE

This instruction manual is for use of the Olympus System Microscope Model BX50. We recommend you read this manual carefully in order to familiarize yourself fully with the use of your microscope so that you can obtain optimum performance.



# IMPORTANT

This unit employs a UIS optical system, and should be used only with UIS eyepieces, objectives, and condensers. Less than optimum performance may result if inappropriate accessory are used.

## 1 Getting Ready

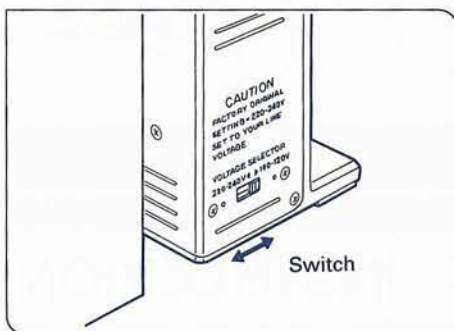
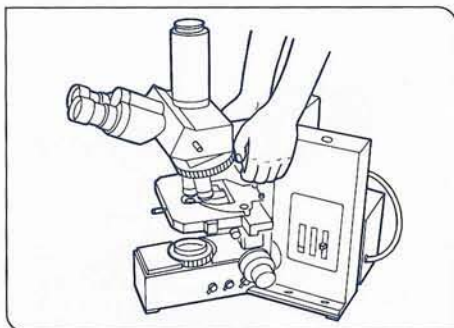



1. The microscope is a delicate instrument. Handle it carefully and protect it from physical shock.
2. The BX50 can be used with up to two intermediate tubes (e.g., a U-CA magnification changer and/or U-EPA eyepoint adjusters). However, be sure to read the instructions provided with the respective intermediate tube for restrictions when using two tubes in series on top of each other.
3. Avoid locations that are exposed to direct sunlight, high temperature or humidity, dusty places, and places that are subject to strong vibrations. Make sure that the work surface is flat and level. (Ambient temperature and humidity should be in the range 0 – 40°C, 30 – 90%.)
4. When moving the microscope, carry it with both hands by holding it at the arm as shown at left. Handle it carefully.
  - ★ Damage to the microscope may result if you hold it by the stage, coarse adjustment knob, or lamp housing. Please be very careful.
5. **Set the voltage selector switch on the rear of the base to 100 – 120V or 220 – 240V position to match the local line voltage using a flat-blade screwdriver. (Before shipment from the factory, the voltage selector switch is set to 220 – 240V position).** (See figure at left)
6. Ground the unit to avoid potential shock hazard.
7. For safety's sake, always turn off the main switch and disconnect the power cord before changing the halogen bulb or fuse.

## 2 Care and Storage

1. Clean lenses by wiping lightly with gauze. To remove fingerprints or other oils, dampen the gauze with a very small quantity of a 7 parts ether/3 parts alcohol solution, or with Xylol.
  - ★ Since ether and alcohol are highly flammable, be careful to keep these chemicals away from an open flame and possible sources of electrical sparks, such as power switches.
2. Do not use organic solvents to clean the microscope. To clean plastic parts, use a neutral detergent.
3. Do not disassemble any part of the microscope.
4. When not using the microscope, keep it covered with the provided dust cover.

## 3 Symbols on the Microscope Frame

Mark	Meaning
	Indicates that the surface becomes hot, and should not be touched with bare hands.
	Before using, carefully read the instruction manual.
	Indicates a potential fire hazard; when replacing fuse, be sure replacement fuse is of the specified rating.
I	Main switch ON
O	Main switch OFF

**CAUTION:** If the equipment is used in a manner not specified by this manual, the safety of the equipment may be impaired.

# CONTENTS

<b>1</b>	<b>NOMENCLATURE</b>	1	<b>1</b>
<b>2</b>	<b>ASSEMBLY</b>	2	<b>2</b>
	2-1 Assembly Diagram .....	2	
	2-2 Assembly Procedure .....	3	
<b>3</b>	<b>CONTROLS</b>	7	<b>3</b>
<b>4</b>	<b>SUMMARY OBSERVATION PROCEDURE</b>	9	<b>4</b>
<b>5</b>	<b>USING THE CONTROLS</b>	11	<b>5</b>
	5-1 Base .....	11	
	5-2 Stage .....	14	
	5-3 Observation Tube .....	16	
	5-4 Condenser .....	18	
	5-5 Adjustment Knobs .....	20	
	5-6 Immersion Objectives .....	21	
	5-7 Photomicrography .....	21	
<b>6</b>	<b>SPECIFICATIONS</b>	23	<b>6</b>
<b>7</b>	<b>OPTICAL CHARACTERISTICS</b>	24	<b>7</b>
<b>8</b>	<b>TROUBLESHOOTING GUIDE</b>	25	<b>8</b>

# 1 NOMENCLATURE

1

NOMENCLATURE

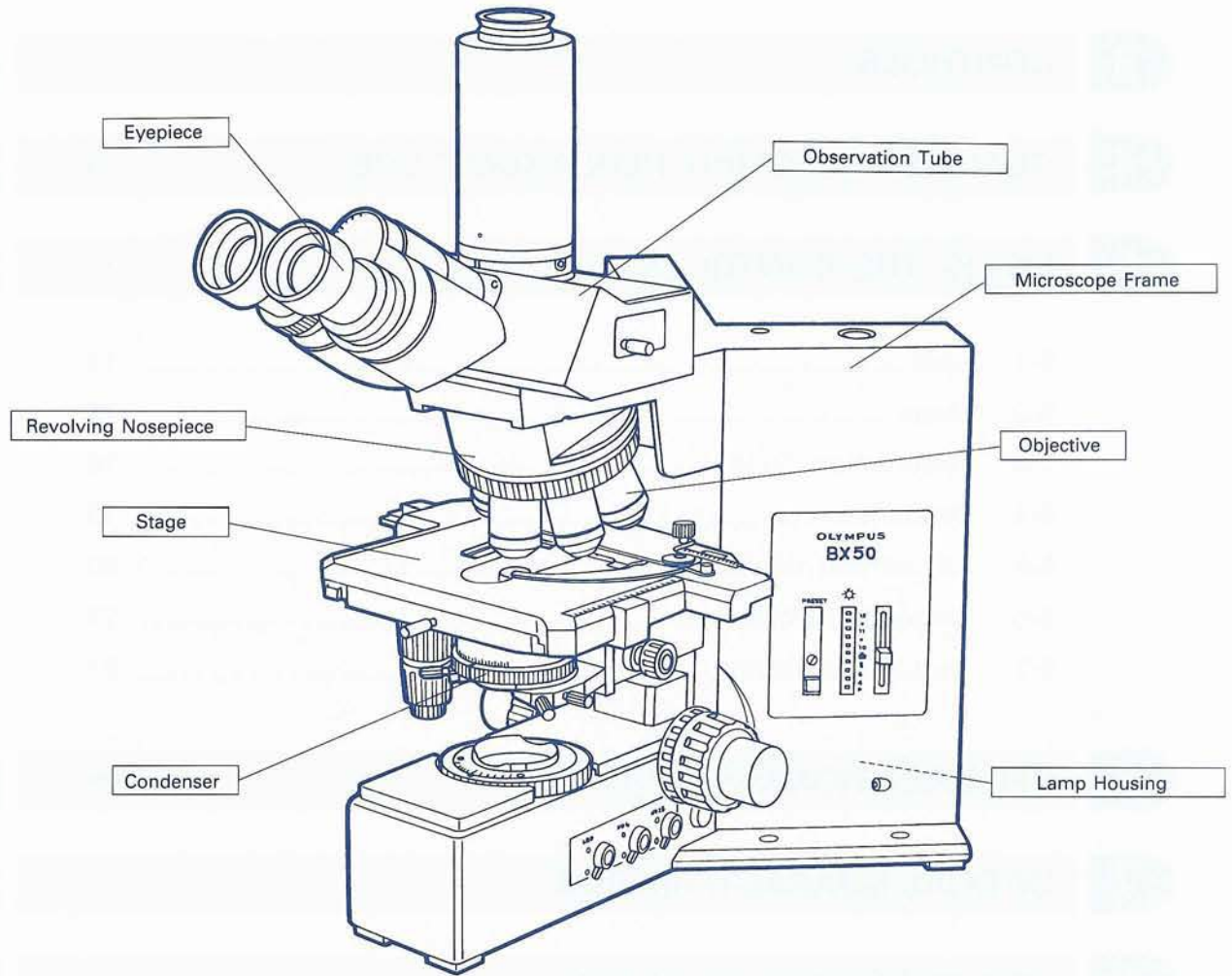

# 2 ASSEMBLY

## 2-1 Assembly Diagram

The diagram below shows how to assemble the various modules. The numbers indicate the order of assembly.

★ When assembling the microscope, make sure that all parts are free of dust and dirt, and be very careful to avoid scratching any parts or touching glass surfaces.

2

ASSEMBLY

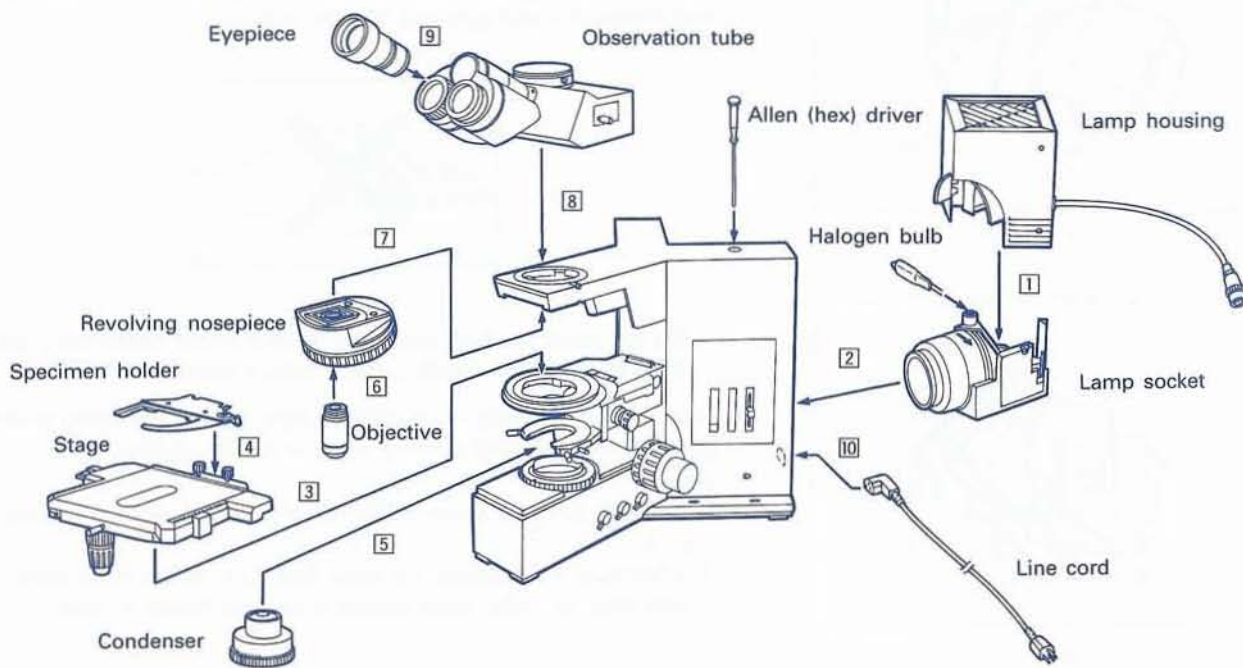

## 2-2 Assembly Procedure

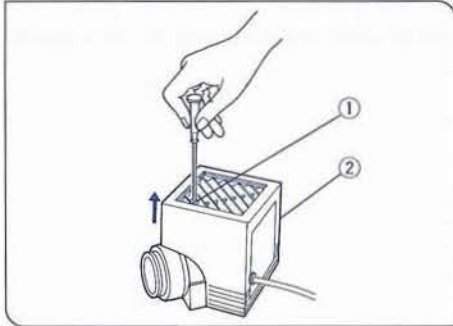

Fig. 1

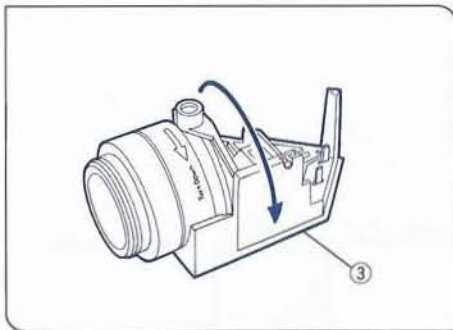

Fig. 2

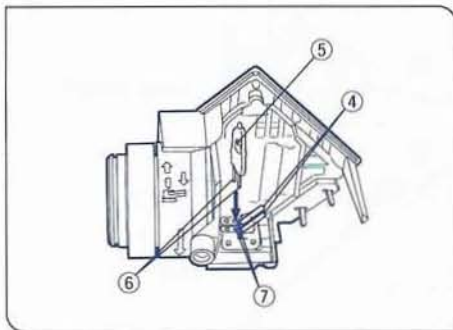

Fig. 3

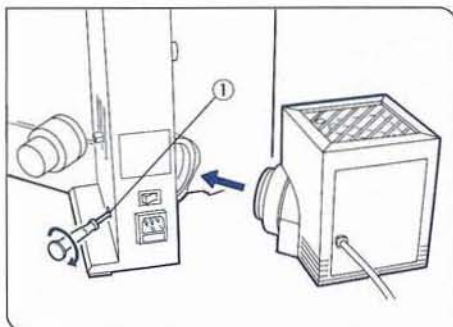

Fig. 4

### 1 Install the Halogen Bulb

(Figs. 1,2,3)

The bulb used in this microscope is a 12V, 100W HAL halogen bulb (Phillips 7724).

1. Fully loosen the lamp housing clamping screw ① on top of the lamp housing cover with the provided Allen (hex) driver. (Fig. 1)
2. Lift the lamp housing cover ② upward and remove it.

3. Turn the lamp socket ③ 90° in the direction indicated by the arrow. (Fig. 2)
4. Holding the bulb with gloves or a piece of gauze, depress the bulb clamping levers ④ and insert the bulb pins ⑥ into the pin holes ⑦ and release the clamping levers. (Figs. 2,3)

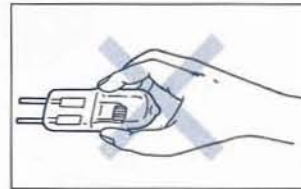

★ Do not touch the bulb with your fingers. If you accidentally get fingerprints on the bulb, wipe it with a piece of soft cloth.

5. Align the lamp housing cover with the lamp socket positioning guide ⑦ and slide the lamp housing cover onto the housing base from above.

Tighten the clamping screw while pressing downward on the cover. (Fig. 1)

★ Whenever you replace the bulb, first turn off the main switch and wait for bulb, lamp socket and lamp house to cool.

### 2 Mount the Lamp Housing on the Microscope

1. Using the Allen (hex) driver, fully loosen the lamp housing clamping screw ① on the side of the microscope. (Fig. 4)
2. Fully insert the lamp housing collector into the microscope to where it touches the lamp housing bracket on the back of the base, then fasten the clamping screw.

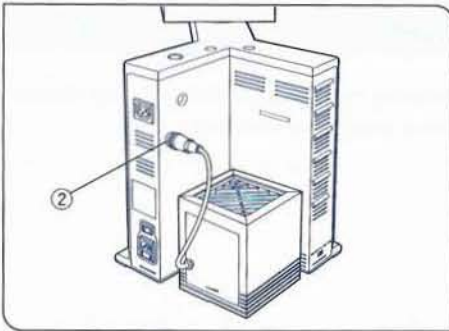

Fig. 5

3. Attach the connected cord plug into the power connector ② on the microscope. Make sure that the connector is tight. (Fig. 5)

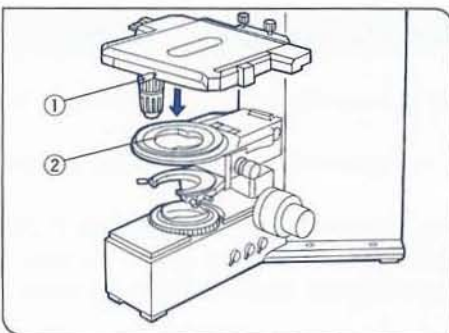

Fig. 6

### 3 Attach the Stage (Fig. 6)

1. Fully loosen the clamping screw ① on the stage.
2. Carefully lower the stage into the round sleeve on the substage, then tighten the clamping screw.

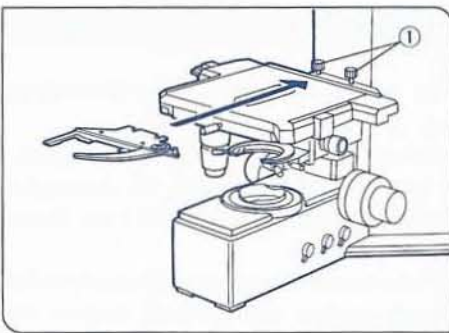

Fig. 7

### 4 Attach the Specimen Holder (Fig. 7)

1. Loosen the specimen holder clamping screws ① without exposing the threads.
  - ★ Be careful to avoid loosening the specimen holder clamping screws too much. If you loosen the screws too much, the threads will prevent complete insertion of the specimen holder.
2. Align the slot in the specimen holder with the clamping screws, then slide the specimen holder backwards as far as it will go.
  - ★ Slide the specimen holder all the way back or it will not be positioned properly.
3. Tighten the specimen holder clamping screws.

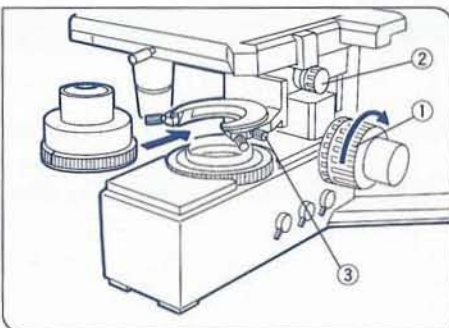

Fig. 8

### 5 Attach the Condenser (Fig. 8)

1. Turn the coarse adjustment knob ① to raise the stage to its upper limit.
2. Turn the condenser height adjustment knob ② to lower the condenser holder to its lower limit.
3. Fully loosen the condenser clamping screw ③.
4. Holding the condenser with the scale markings in front, carefully position the condenser and insert it into the condenser sleeve as far as it will go.
5. Tighten the condenser clamping screw, then raise the condenser to its upper limit, with the condenser height adjustment knob.
  - ★ When mounting the U-SC swing-out Achromat condenser, align the positioning pin at the back of the condenser with the slot in the condenser sleeve.
  - ★ When using the U-SC swing-out Achromat condenser or the U-UCD universal condenser, swing the front lens out of the way before inserting the condenser.

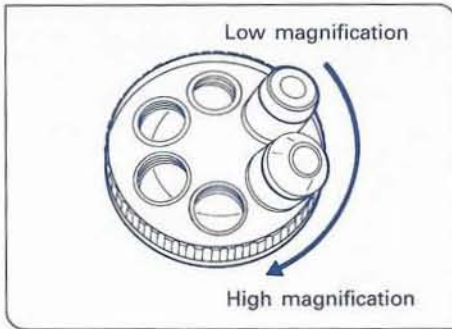

Fig. 9

## 6 Mount the Objectives (Fig. 9)

Mount the objectives on the revolving nosepiece so that the magnification increases from low to higher in a clockwise direction.

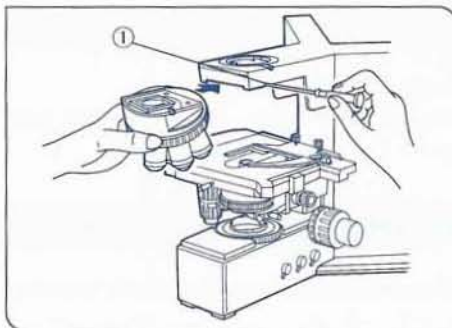

Fig. 10

## 7 Mount the Revolving Nosepiece (Fig. 10)

1. Turn the coarse focus knob to lower the stage to the bottom of its travel range.
2. Using the Allen (hex) driver, fully loosen the nosepiece clamping screw ① on the microscope.
3. Carefully slide the nosepiece into place from directly in front of the microscope, pushing it forward until it comes up against the stop.
4. Fasten the nosepiece by tightening the nosepiece clamping screw.

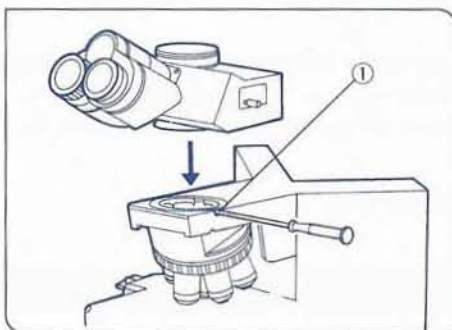

Fig. 11

## 8 Mount the Observation Tube (Fig. 11)

1. Use the provided Allen (hex) driver to fully loosen the observation tube clamping screw ①.
2. Insert the circular dovetail mount at the bottom of the observation tube into the opening on the microscope frame, setting the observation tube into place so that the binocular eyepieces are at the front. Clamp the observation tube by tightening screw.
  - ★ If the direction of stage movement does not match the direction of image movement when making observations, loosen the observation tube clamping screw slightly and adjust by turning the tube while observing the image.

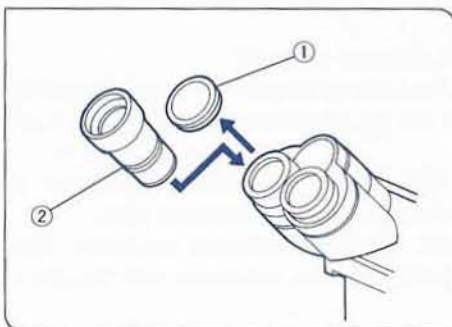

Fig. 12

## 9 Mount the Eyepieces (Figs. 12,13)

1. Remove the eyepiece cap ①.
2. Insert the eyepieces ② into the eyepiece sleeves as far as they will go. (Fig. 12)
  - ★ Eyepiece with helicoid can not be used with U-TBI tilting tube.



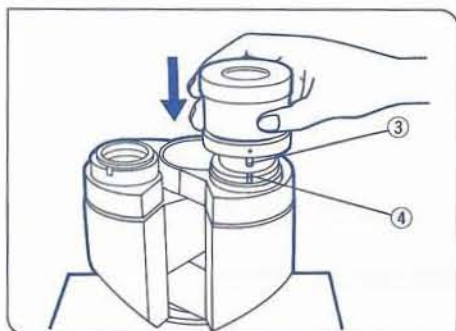

Fig. 13

When using the trinocular observation tube (U-TR30) or super-wide angle trinocular observation tube (U-SWTR)

When using a finder eyepiece or an eyepiece with diopter adjustment, inset it into the right-hand eyepiece sleeve. When doing so, make sure that the eyepiece positioning pin ③ fits into the notch ④ at the bottom of the eyepiece sleeve. (Fig. 13)

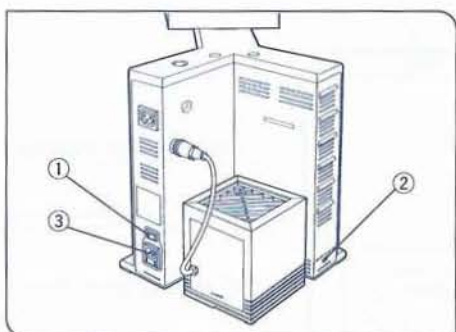

Fig. 14

### 10 Connect the Power Cord

(Fig. 14)

1. Check that the main switch ① is in the OFF position.
2. Before shipment from the factory, the voltage selector switch ② is set to the 200-240V position. In case your local line voltage is 100-120V, move the lever to the 100-120V position using a flat-blade screwdriver.
3. Plug the power cord into the receptacle ③.
4. Connect the power cord's ground wire to the ground terminal on the power outlet you will be using with the microscope, then plug the power cord into the wall outlet.

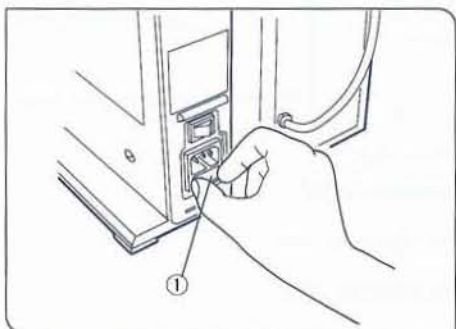

Fig. 15

### 11 Replace Fuses

(Figs. 15,16)

Before replacing fuses, turn off the power switch and unplug the power cord.

1. Remove the fuse holder ① by squeezing it at the sides and pulling outward. (Fig. 15)

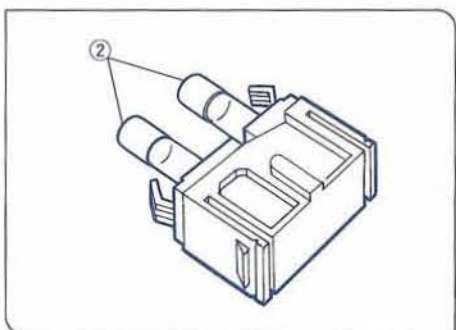

Fig. 16

2. Replace both fuses ② with new ones. (Fig. 16)  
★ Use only fuses of the specified rating.

Fuse rating: 250V 5A Time Lag, Hi-breaking-Capacity (Littelfuse 215005)

# 3 CONTROLS

3

CONTROLS

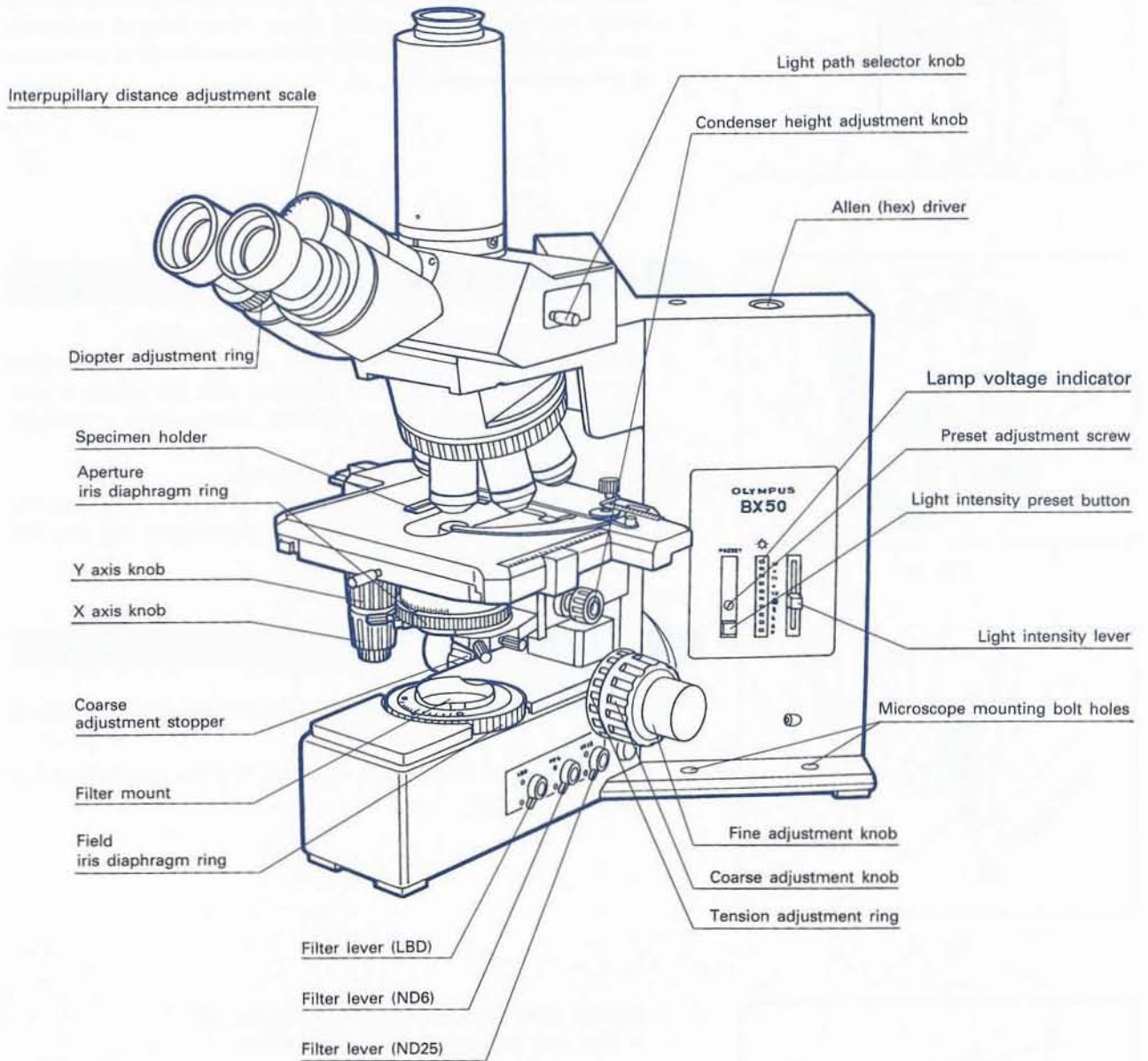

Outlet for U-DO, MDO  
This outlet can only use for both models U-DO and U-MDOB.

Main switch

Power cord receptacle

Fuse holder

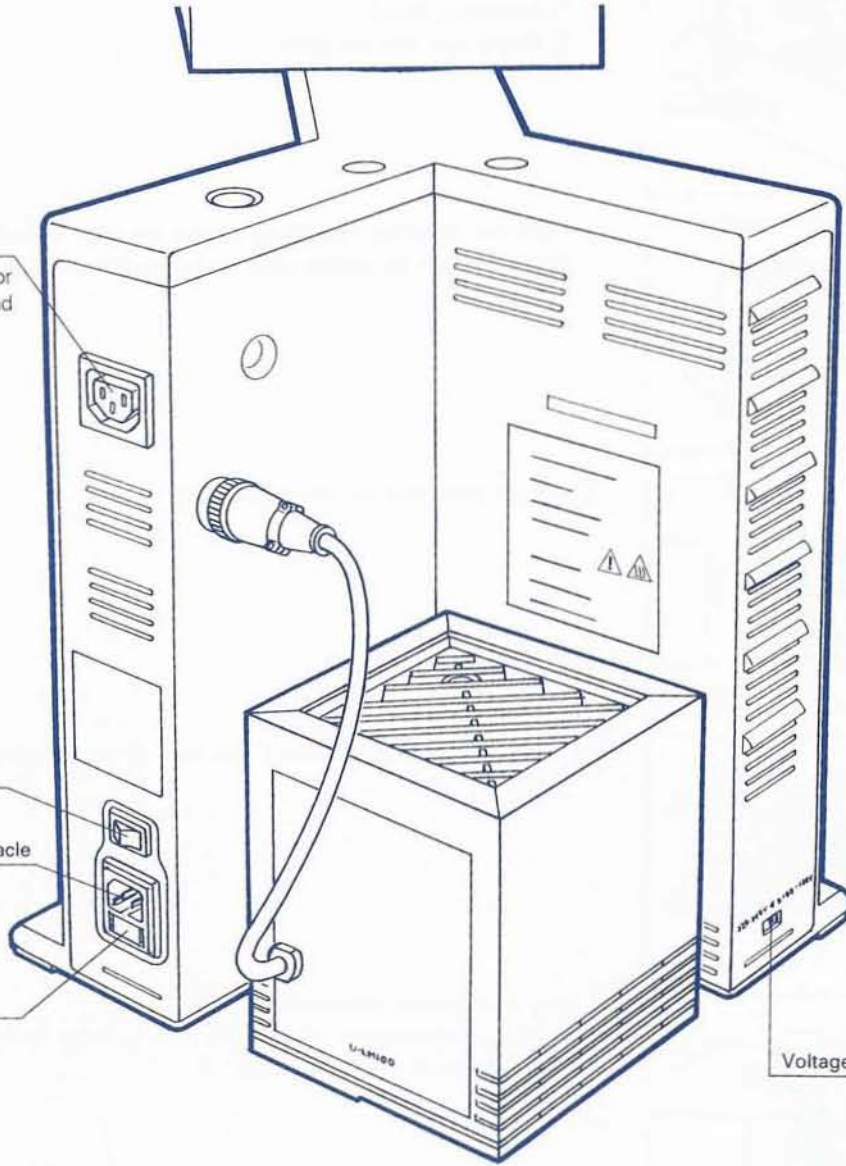

Voltage selector switch

# 4 SUMMARY OBSERVATION PROCEDURE

## 4

SUMMARY OBSERVATION PROCEDURE

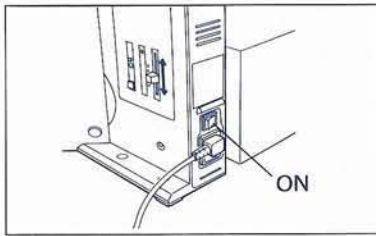

1. Turn on the main switch and adjust the brightness with the light intensity lever. (When doing this, keep the light intensity preset button on.) (Page 11)

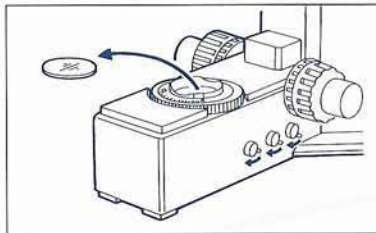

2. Move all filters out of the light path. (Pages 11,12)
  - 1) Accessory filters
  - 2) Filters built into the base

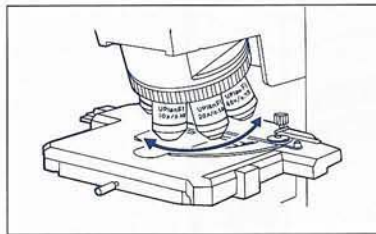

3. Turn the revolving nosepiece so that the 10X objective is in the light path. Watch out for an audible click in that position.

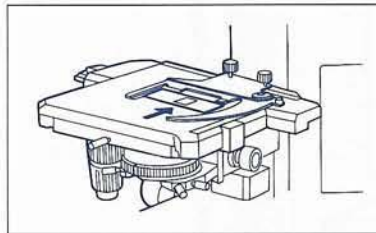

4. Place a specimen on the stage. (Page 14)

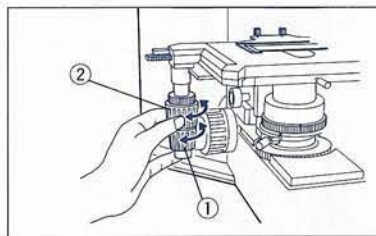

5. Turn the X axis knob ① and Y axis knob ② to move the specimen into the light path.

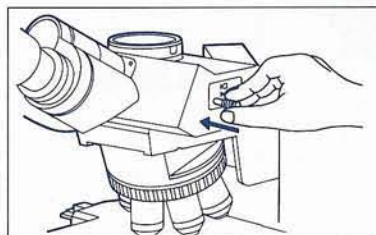

[Using a trinocular observation tube]

6. Push the observation tube's light path selector knob to "binocular eyepiece 100%" (the IN position). (Page 17)

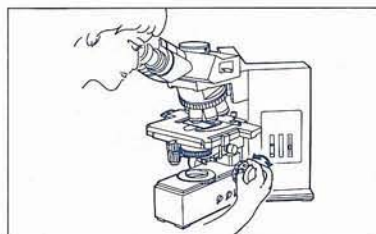

7. Looking through the right eyepiece with your right eye, turn the coarse adjustment knob to bring the specimen into focus. After obtaining approximate focus, use the fine adjustment knob to make fine adjustments. (Page 20)

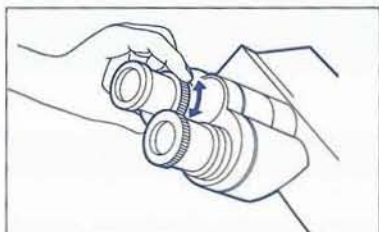

8. Looking through the left eyepiece with your left eye, turn the diopter adjustment ring to focus the specimen. (Page 16)

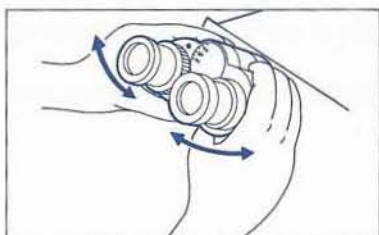

9. Adjust the interpupillary distance of the eyepieces. (Page 16)

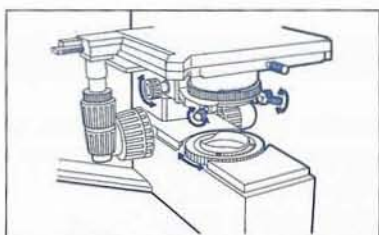

10. Adjust condenser centering and focus. (Page 18)

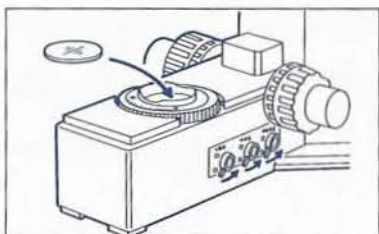

11. Engage the objective to be used for observation and adjust the light intensity to the desired level, then readjust the focus.
12. Place your choice of filters into the light path. (Pages 11,12,13)
  - 1) Accessory filters
  - 2) Filters built into the base

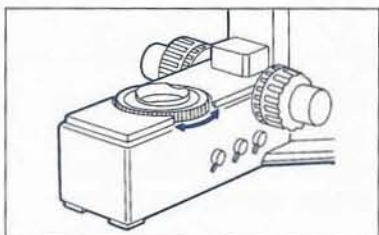

13. Adjust the field iris diaphragm. (Page 18)

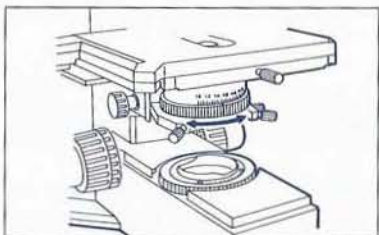

14. Adjust the aperture iris diaphragm. (Page 19)

# 5 USING THE CONTROLS

## 5-1 Base

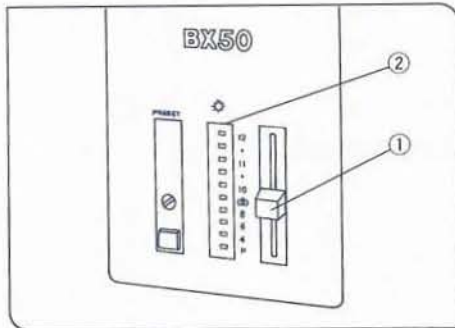

Fig. 17

### 1 Voltage indicator (Fig. 17)

1. Sliding the light intensity lever ① upward increases the voltage, making illumination brighter.
2. The numerals to the right of the LEDs of the lamp voltage indicator ② indicate the voltage.
  - For photomicrography, the voltage should be approximately at the level indicated by the camera mark (  ).



Fig. 18

### 2 Setting the Light Preset Button (Fig. 18)

The light preset button ① makes it possible to set the light intensity to a preselected level regardless of the position of the light intensity lever.

1. Push the light preset button ① to the ON position.  
(The face of the switch lights when the switch is ON.)
2. Using a small screwdriver, turn the preset adjustment screw to obtain the required light intensity. Turning the screw clockwise increases intensity.
3. Switch the light preset button OFF and brightness returns to the level set by the light intensity lever.
  - ★ The light intensity lever does not affect brightness while the light preset button is ON.

### Using the Light Preset Button

The light preset button allows you to temporarily adjust brightness to a preset level for applications such as photomicrography, making it unnecessary to manually adjust the brightness each time you take a photograph.

- Before shipment from the factory, the preset level is set to an intensity that is suitable for photomicrography.
- The light preset button is also useful when using two different objectives alternately, allowing you to avoid manually adjusting the brightness each time you change magnification.

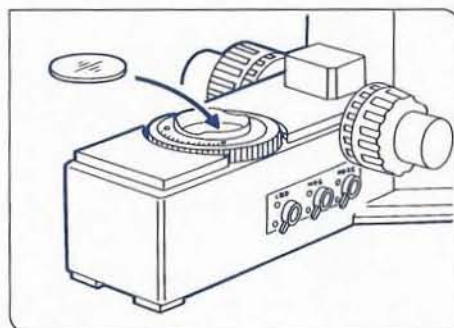

Fig. 19

### 3 Use of Accessory Filters

You can place two 45 mm diameter filters into the filter holder on the light exit at the base of the microscope. If you need to use multiple filters at the same time, use a filter cassette.

- ★ When using a filter cassette, you can additionally use a single filter with a thickness of less than 3 mm over the light exit glass.

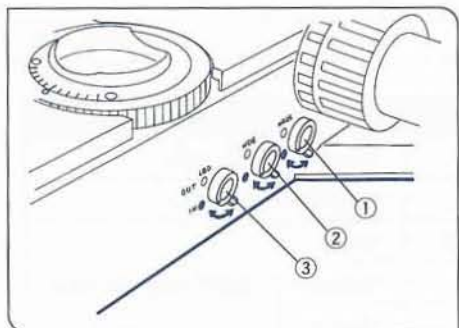

Fig. 20

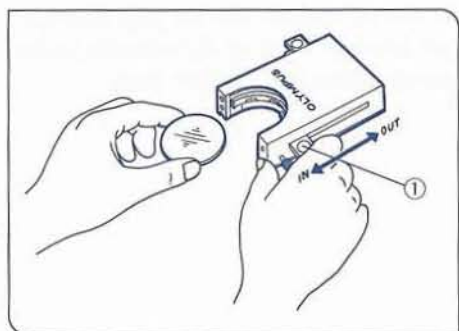

Fig. 21

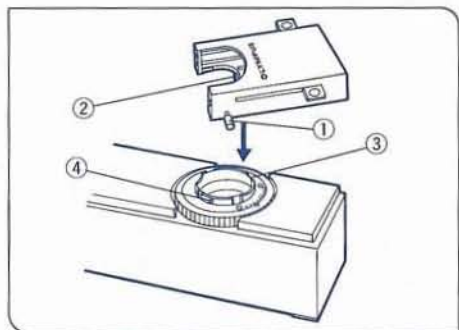

Fig. 22

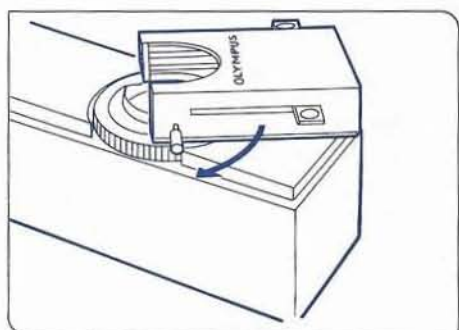

Fig. 23

**Using Built-in Filters**

(Fig. 20)

Three filters are built into the base of the microscope. These filters are moved into and out of the light path using the levers located on the right side of the base.

Each of the three filters ① to ③ is placed into the light path by turning its lever so that the • mark on the lever is positioned adjacent to the • mark on the base, and is moved out of the light path by turning the lever so that the ◦ mark is located adjacent to the ◦ mark on the base. Each of the three levers can be switched IN and OUT independently of the others.

	Filter type
①	ND25
②	ND6
③	LBD

**Using the Filter Cassettes (option)**

(Figs. 21,22,23,24)

If you need to place 3 or more filters over the light exit window, use the filter cassette.

**Loading Filters Into the Filter Cassette**

(Fig. 21)

The filter cassette has two filter levers on the right side and one on the left side.

The filter cassette accommodates filters with a diameter of 45 mm and a thickness of 2.7 mm or less.

1. Move all filter levers to the OUT position except for the one belonging to the slot into which the filter is to be inserted.
2. Slide lever ① to the IN position. Make sure that it clicks securely into place.
3. Holding the lever in the position shown, put the filter into the cassette by inserting it in the direction indicated by the arrow.
4. Place the other two filters in the same manner.

**Mounting the Filter Cassette**

(Figs. 22,23)

1. Loosen the filter cassette clamping screw ①. (Fig. 22)
2. Holding the filter cassette above the light exit glass, align the key ② with the slot ③ and press the filter cassette into place from above.
3. Rotate the filter cassette to align its sides with the base. (Fig. 23)
4. Align the clamping screw ① with the positioning hole ④ on the light exit, then tighten the screw to fasten the filter cassette.

★ When the filter cassette is installed, the stage may hit it when lowered. Therefore, exercise caution when lowering the stage with the filter cassette installed.

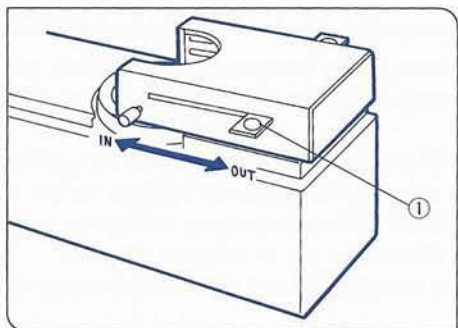

Fig. 24

## Using the Filter Cassette

(Fig. 24)

Usable filters	Applications	
45LBD-IF	Color balancing filter	
45ND-6, 45ND-25	Neutral density filter	
45G-530, 45G-533, 45IF550	Green	B&W contrast filter
45Y-48	Yellow	
45O-560	Orange	
45C-3, 45KB-3	Daylight filter	

Up to three of the above filters can be inserted into the filter cassette. Moving the levers ① on the left and right sides of the cassette to the IN position moves the corresponding filter into the light path.



## 5-2 Stage

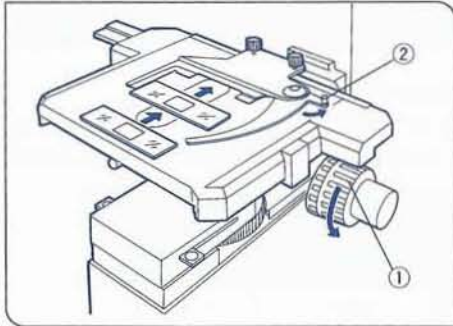

Fig. 25

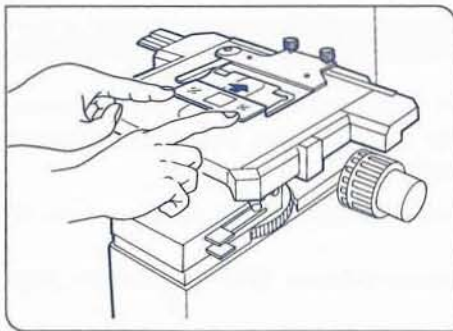

Fig. 26

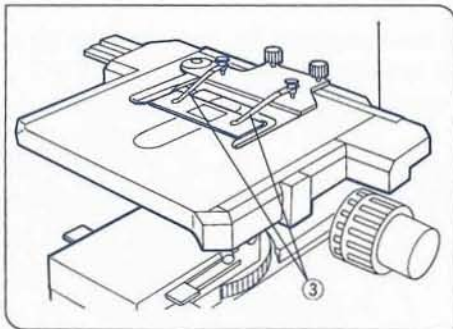

Fig. 27

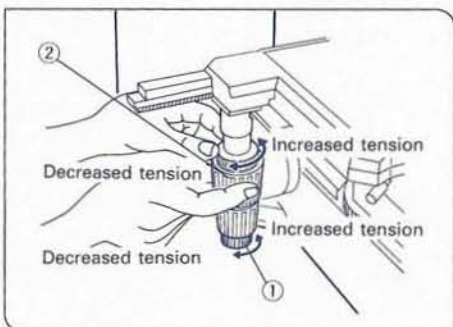

Fig. 28

### 1 Placing of Specimen Slides

#### Specimen Holder for 2 Specimen Slides

(Fig. 25)

1. Lower the stage by turning the coarse adjustment knob ①.
2. Open the lever ② on the specimen holder and slide the specimen slides on to the stage from the front.
3. After sliding the slides in as far as they will go, gently close the lock lever.

#### Specimen Holder for Single Slides

(Figs. 26,27)

The specimen can easily be placed by sliding it into the specimen holder from the front. (Fig. 26)

- ★ With single slide observations, the maximum slide dimensions are 26 X 76 mm, with a thickness of 0.9 to 1.4 mm and cover glass thickness of 0.17 mm.
- ★ When observing large specimens slides, remove the specimen holder and place the specimen directly on the stage.

#### Using an Oil Immersion Objective

Adsorption of immersion oil can cause the specimen to float. In such cases, it is recommended to use the optional specimen clip (BH2-SCB-3) for oil immersion objectives ③. (Fig. 27)

### 2 Adjust the Tension of the X and Y Axes Knobs

(Fig. 28)

The tension of the X and Y axes knobs can be individually adjusted. Turning the X adjustment knob ① or the Y adjustment knob ② in the direction of the arrow increases tension, and turning it in the opposite direction reduces tension.

When adjusting the tension, hold the X and Y axes knobs to keep them from turning along with the tension adjustment knobs.

- ★ If the tension is adjusted too tight, a creaking sound may be heard during stage travel or the stage may move back when stopped.

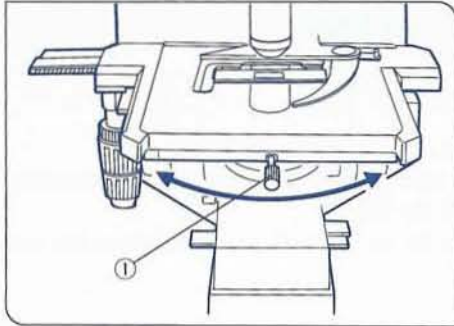

Fig. 29

### 3 Rotating the Stage (Fig. 29)

1. Slightly loosen the stage clamping screw ①.
2. The stage can be rotated by turning it with the stage clamping screw.
  - The rotation angle changes depending on position of the stage knobs.

	Rotation angle	
	Clockwise	Counter-clockwise
Right hand knobs	230°	20°
Left hand knobs	20°	230°

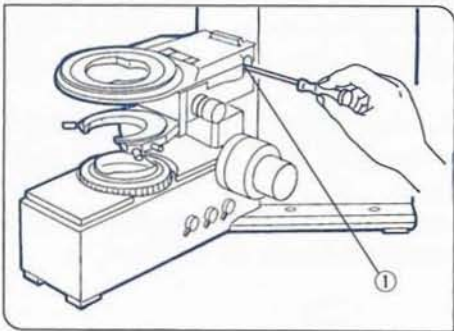

Fig. 30

### 4 Stage Height Adjustment (Figs. 30,31)

By lowering the stage height, the microscope will accommodate specimens with height up to 40 mm. This is useful when observing metallurgical specimens and other thick objects.

1. Lower the stage to the lower limit, then remove the stage from the microscope. (See page 4.)
2. Loosen the stage bracket clamping screw ① and remove the stage bracket. (Fig. 30)

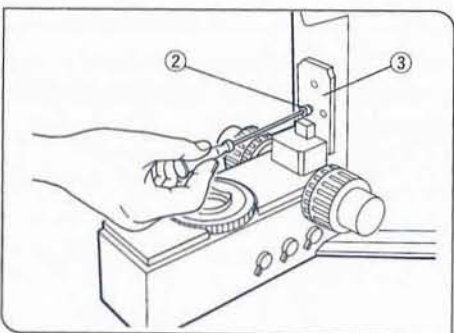

Fig. 31

3. Turn the coarse adjustment knob and raise the focusing block ③ to where the stopper screw ② in the arm becomes visible. (Fig. 31)
4. Using the Allen (hex) driver, loosen and remove the upper stopper screw ②.
5. Reattach stage bracket and stage.  
Store the removed stopper screw ② in a safe place so that you do not lose it.

### 5-3 Observation Tube

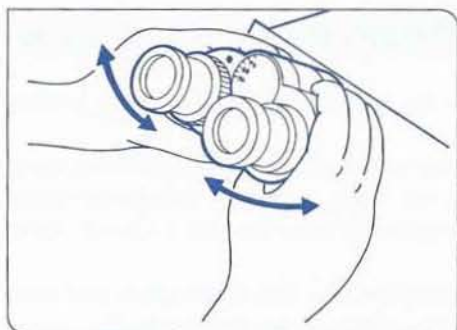

Fig. 32

#### 1 Interpupillary Distance Adjustment (Fig. 32)

While looking through the eyepieces, adjust the binocular movement to where the left and right view fields are the same. The index dot • indicates the interpupillary distance.

Note your interpupillary distance so that it can be quickly duplicated.

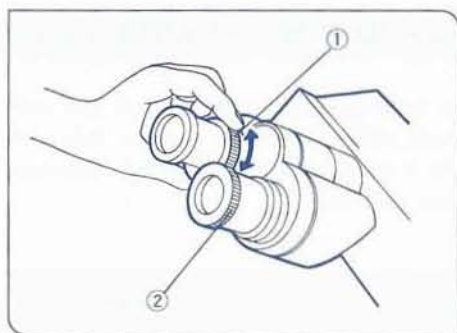

Fig. 33

#### 2 Diopter Adjustment (Figs. 33,34)

1. Looking through the right eyepiece with your right eye, focus on the specimen using the coarse and fine adjustment knobs.
2. Looking through the left eyepiece with your left eye, turn the diopter adjustment ring ① to where the specimen is in focus. (Fig. 33)

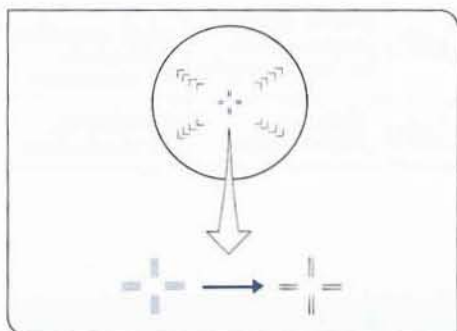

Fig. 34

#### Using a Finder Eyepiece

1. Looking through the right eyepiece with your right eye, turn the knurled ring on top of the eyepiece until you see two distinct sets of reticles in the field of view. (Figs. 33,34)
2. Looking through the right eyepiece, turn the coarse adjustment knob to focus on the specimen and reticles.
3. Looking through the left eyepiece with your left eye, turn the diopter adjustment ring ① using a finder eyepiece

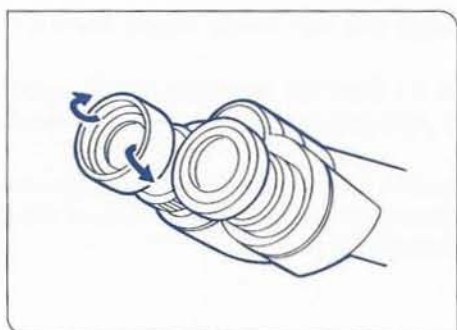

Fig. 35

#### 3 Using the Eye Shades (Fig. 35)

##### When not Wearing Eyeglasses

With the eye shades in their normal extended position, observe with one's eyes close to the eye shades.

##### When Wearing Eyeglasses

Hold the eye shade outward with both hands. (Fig. 35)

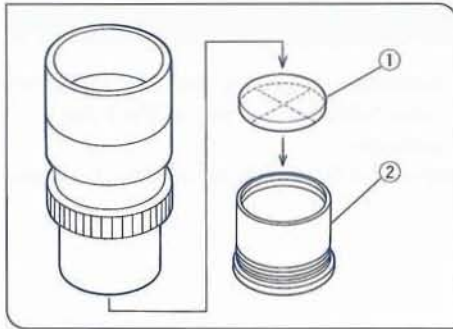

Fig. 36

#### 4 Use of Eyepiece Micrometers

(Fig. 36)

Eyepiece micrometers can be inserted on WH10X-H and WH10X eyepieces.

Following Fig. 36, unscrew the micrometer frame ② from the eyepiece, place a micrometer ① into the frame. Screw the micrometer frame into the eyepiece as it was before. (Please use  $\phi 24 \times 1.5$  mm micrometers.)

★ The micrometer is inscribed on one side of the glass and must be placed with the inscribed side facing the frame ②.

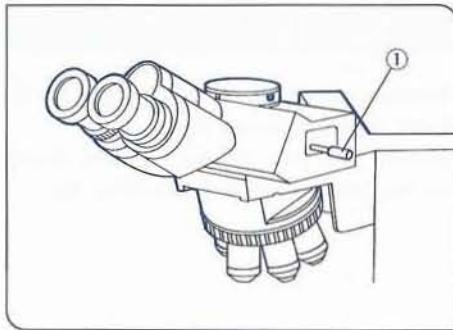

Fig. 37

#### 5 Light Path Selection (U-TR30, U-SWTR) (Fig. 37)

Slide the light path selector knob ① to select the desired light path. The selector knob is ordinarily set at the middle position. With dark specimens, push the knob in. If additional light is needed for television or photomicrography, pull the knob out.

Light path selector knob	Indication	Intensity ratio	Application
Pushed in		100% at binocular eyepieces	Observation of dark specimens
Middle position		20% at binocular eyepieces, 80% for TV/photography	Observation of bright specimens, photography, TV observation
Pulled out		100% for TV/photography	Photography, TV observations

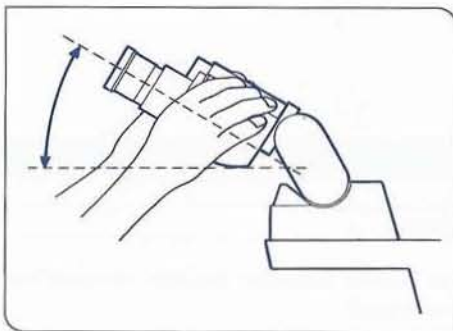

Fig. 38

#### 6 Tilt Adjustment (U-TBI)

(Fig. 38)

Adjust the height and tilt of the observation tube to the most comfortable viewing position.

Holding the binocular assembly with both hands, raise or lower it to the desired position.

★ Do not attempt to force the binocular assembly past the upper or lower stop positions. Applying excessive force could destroy the mechanism.

★ The U-TBI tilting observation tube is not recommended for use in combination with various intermediate tubes because of slight vignetting in the peripheral field of view.

## 5-4 Condenser

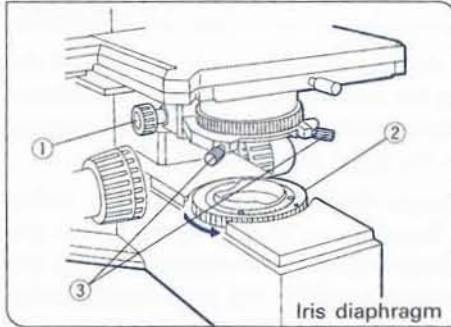

Fig. 39

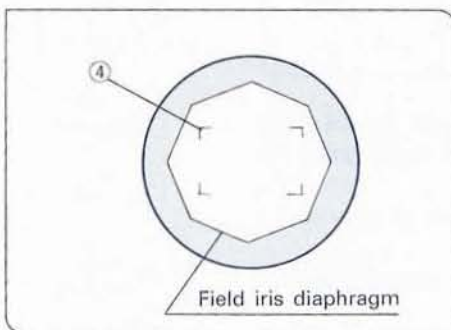

Fig. 40

### 1 Condenser Centration

(Figs. 39,40,41,42)

1. Turn the condenser height adjustment knob ① and raise the condenser to its upper limit. (Fig. 39)
2. Focus on the specimen using the 10X objective.  
★ When using the U-SC swing-out condenser, move the front lens into the light path.
3. Rotate the field iris diaphragm ring ② in the direction of the arrow to reduce the aperture.
4. Turn the condenser height adjustment knob ① to where the image of the iris diaphragm is visible in sharp focus.
5. Turn the two condenser centering screws ③ to move the image of the field iris diaphragm to the center of the field of view.
6. Gradually open the field iris diaphragm. The condenser is properly centered if the iris image is centered and inscribed in the field of view..
7. During actual use, increase the field stop slightly so that its image is just outside the field of view.

#### Field Iris Diaphragm

(Fig. 40)

The field iris diaphragm restricts the diameter of the beam of light entering the condenser and thus excludes extraneous light, improving image contrast. The diameter of the field iris should be adjusted for objective power to the extent that it lies just outside the field of view. "Compatibility of objectives and condensers" on the next page.)

When photographing specimens, stop the field stop down to where it is somewhat larger than the film format ④ to obtain even better results.

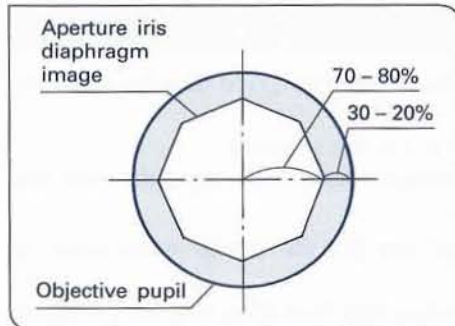

Fig. 41

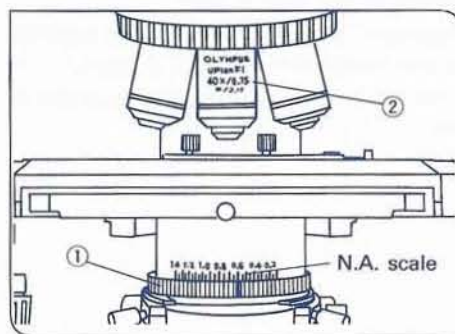

Fig. 42

### Aperture Iris Diaphragm

(Figs. 41,42)

- The aperture iris diaphragm determines the numerical aperture of the illumination system. Matching the numerical aperture of the illumination system with that of the objective provides better image resolution and contrast, and also increases the depth of focus.
- Since the contrast of microscopic specimens is ordinarily low, setting the condenser aperture iris diaphragm to 70~80% of the N.A. of the objective in use is usually recommended. When necessary, adjust this ratio by removing the eyepiece and peering into the eyepiece sleeve to see the image shown in Fig. 41.

### Using the Numerical Aperture Scale

Set the condenser numerical aperture ① to about 80% of the NA value ② indicated on the objective. (Fig. 42)

Example: With the Plan 40X (NA 0.65), set the scale to  $0.65 \times 0.8 = 0.5$ .

### Compatibility of Objectives and Condensers

Objective magnification	Condenser			
	Achromat U-AC	Achromat/aplanat U-AAC	Swing-out achromat U-SC	Ultra-low magnification U-ULC
1.25X	Usable to FN22	Usable	Usable by moving front element out of the light path*1	Usable
2X				
4X				
10~60X	Usable	Usable	Front element in light path NA not fully adequate*2	
100X				

\*1 When using the U-SC swing-out achromat condenser together with the 2X or 4X objective, fully open the condenser aperture and use the field iris diaphragm in the base as aperture diaphragm.

\*2 Although slightly inadequate NA results in a somewhat darker field of view with a 100X objective, the combination is usable.

- To obtain better illumination, use of the U-ULC is recommended in photomicrography when using the 2X or 4X objective.

## 5-5 Adjustment Knobs

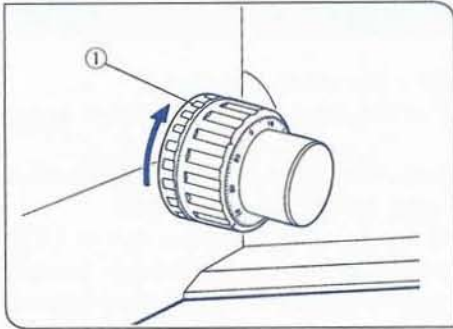

Fig. 43

### 1 Adjusting the Coarse Adjustment Knob Tension (Fig. 43)

Adjust the coarse adjustment knob tension using the tension adjustment ring.

The coarse adjustment knob tension is preadjusted for easy use. However, if desired you can change the tension using the tension adjustment ring ①. Turning the ring in the direction of the arrow increases tension, and vice versa.

The tension is too low if the stage drops by itself or focus is quickly lost after adjustment with the fine adjustment knob. In this case, turn the ring in the direction of the arrow to increase tension.

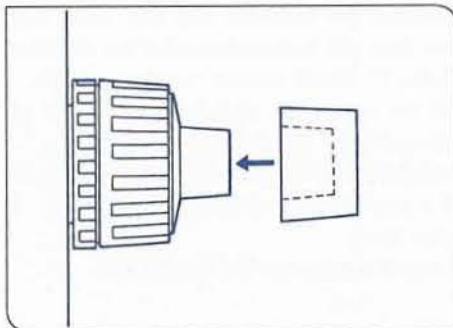

Fig. 44

### 2 Using the Fine Adjustment Knob Rubber Cap (Fig. 44)

Ordinarily, the fine adjustment knob is used with the rubber cap attached. However, if space between the knob and the stage knobs is insufficient, the cap may be removed. The cap makes it easier to turn the fine adjustment knob, allowing more accurate focus.

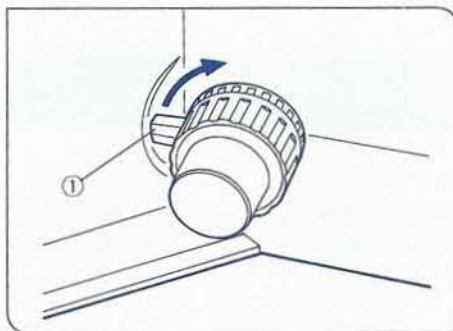

Fig. 45

### 3 Coarse Adjustment Stopper (Fig. 45)

The coarse adjustment stopper serves to keep the objective from bumping into the specimen and to simplify focusing. After focusing on the specimen with the coarse adjustment knob, turn this lever ① in the direction of the arrow to set an upper limit on the coarse adjustment movement. After changing specimens, refocussing is easily accomplished by turning the coarse adjustment knob to the stopper position, then making fine adjustments with the fine adjustment knob.

Stage movement with the fine adjustment knob is not affected by this stopper.

## 5-6 Immersion Objectives

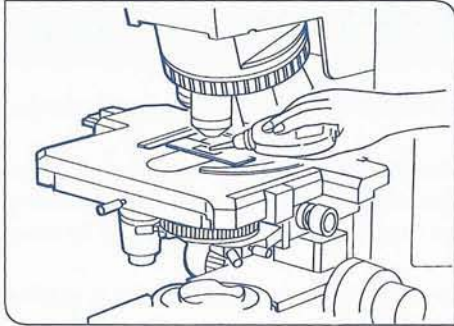

Fig. 46

### 1 Use of Immersion Objectives

(Fig. 46)

1. Focus on the specimen with a low power objective.
2. Place a drop of immersion oil (provided) onto the specimen at the area to be observed.
3. Turn the revolving nosepiece to move the oil immersion objective into the light path, then focus using the fine adjustment knob.

If the condenser marking shows a numerical aperture (NA) of 1.0 or more, the number applies only when oil is present between the slide glass and the top element of the condenser. When oil is not present, the NA is about 0.9.

★ Since any bubbles in the oil will impair the image, make sure that the oil is free of bubbles.

- a. To check for bubbles, remove the eyepiece and fully open field and aperture iris diaphragm, then look at the exit pupil of the objective inside the observation tube. (It should appear round and bright.)
  - b. To remove bubbles, rock the nosepiece slightly to move the oil immersion objective back and forth a few times.
4. After use, remove oil from the objective front lens by wiping it carefully with gauze dampened with a very small quantity of 7 parts ether: 3 parts alcohol solution, or with Xylol.

★ Using too much Xylol can dissolve the lens adhesive.

## 5-7 Photomicrography

- Use a trinocular observation tube (U-TR30) for taking photomicrographs.

Photomicrography can be performed using either the PM-10, the PM-20, or the PM-30 photomicrographic system. Procedures for using the photomicrographic unit are described in respective instruction manual. Procedures specific to this microscope are given below.

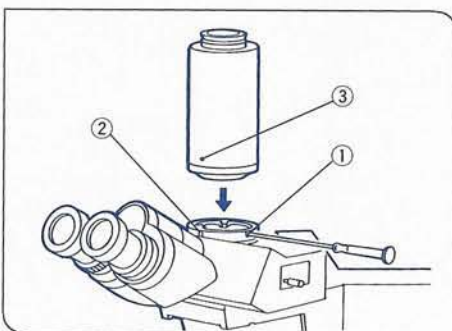

Fig. 47

### 1 Single Port Tube Attachment (U-SPT)

(Fig. 47)

1. Using the Allen driver, loosen the clamping screw ① on the trinocular tube's photo port.
2. Align the vertical index line ② with the index dot ③ on the single port tube, then insert the single port tube into the photo port.
3. Securely tighten the clamping screw ①.



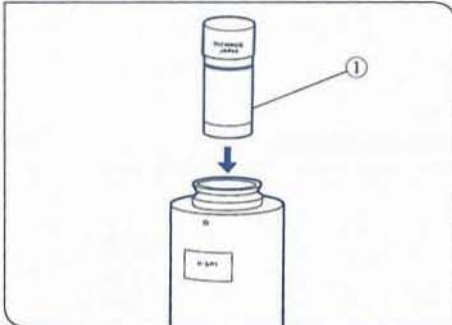

Fig. 48

**2 Photo Eyepiece** (Fig. 48)

Use the PE photo eyepiece for photomicrography. Insert the photo eyepiece ① into the straight photo tube mounted on the trinocular observation tube.

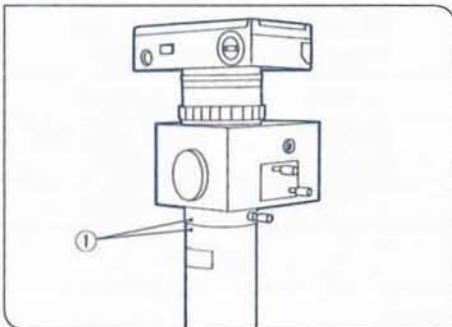

Fig. 49

**3 Mounting the Photographic Unit** (Fig. 49)

Place the photographic unit directly over the circular dovetail of the straight photo tube. Make sure that the index dots ① on the straight photo tube and the unit are aligned, then clamp the unit.

**4 Setting the Observation Tube Light Path**

See page 17 of the "Observation Tube" section.

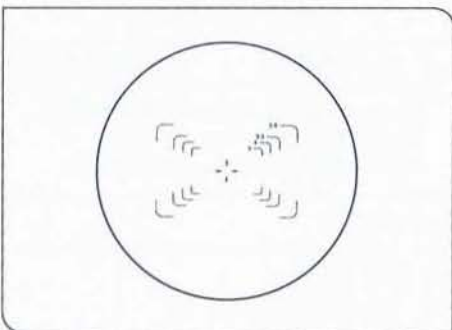

Fig. 50

**5 Focus Adjustment** (Fig. 50)

1. Focusing is done using the binocular eyepiece part of the trinocular observation tube.
  - ★ Whenever you remove the viewfinder from the photographic unit, be sure to install the cap.
2. Insert a finder eyepiece into the right eyepiece sleeve.
3. The finder eyepiece has a built-in focusing lens with four masks, and the focus is practically the same for the focusing lens and the camera film plane. The masks indicate the areas covered, and the numerals next to the masks correspond to the magnification of the photo eyepiece. Different finder eyepieces are available for different cameras. Select the type that is appropriate for the camera being used.
4. Because of the great depth of focus of 1.25X to 4X objectives, use of the illuminated focusing telescope (U-FT) is recommended for accurate focusing.
  - When using low power objectives, focusing may be easier to do using the viewfinder on the photographic unit rather than using the finder eyepiece.

# 6 SPECIFICATIONS

Item	Specification				
(1) Optical system	UIS (Universal Infinity System) optical system				
(2) Light illumination	Built-in transmitted Koehler illumination 12V 100W Halogen bulb (pre-centered) Light intensity DC 2.5V-12.3V (continuous) Light preset switch (setting range 2.5V-12.3V) Power consumption 100-120V/220-240V 2.5/1.3A 50/60 Hz Fuse 250V 5A, Time Lag, Hi-breaking-Capacity type (LITTELFUSE 215005)				
(3) Focusing	Stage movement by roller guide (Rack & Pinion) Stroke per rotation: 0.1 mm (fine), 15 mm (coarse) Full stroke range: 25 mm Upper limit stopper Torque adjustment on coarse handle				
(4) Revolving nosepiece	Type	U-6RE Reversed sextuple		U-D6RE Universal reversed sextuple	
	Attachment	None		DIC prism for transmitted light Analyzer for transmitted light	
(5) Observation tube	Type	U-BI30 Wide field binocular	U-TBI Wide field tilting binocular	U-TR30 Wide field trinocular	U-SWTR Super wide field trinocular
	Field No.	22			26.5
	Tube inclination	30°	5°-35°	30°	
	Interpupillary distance	50 mm - 76 mm			
	Light path	None		3 steps: ① Bi 100% ② Bi 20%, Photo 80% ③ Photo 100%	
(6) Stage	Type	U-SVRS (B) Common axis with low positioned coaxial knobs on the right side (Rectangular ceramic coated stage)	U-SVRD (B) Common axis with low positioned coaxial knobs on the left side (Rectangular ceramic coated stage)	U-SVLS.(B) Common axis with low positioned coaxial knobs on the left side (Rectangular ceramic coated stage)	U-SVLD (B) Common axis with low positioned coaxial knobs on the left side (Rectangular ceramic coated stage)
	Size	135 mm (D) X 180 mm (W)			
	Movement mechanism	Adjustable vertical (Y) and horizontal (X) knob tension Movement range: 52 mm vertically (Y), 76 mm horizontally (X) (Allows observation of full surface of two standard size slides)			
	Specimen holder	Single slide holder	Two slide holder	Single slide holder	Two slide holder
	(7) Condenser	Type	U-AC Abbe achromat condenser	U-SC Swing-out achromat condenser	U-AAC Achromat aplanat condenser
	N.A.	1.25	0.9 - 0.16	1.40	
	Aperture iris diaphragm	With aperture iris diaphragm scale			
	Usable objectives	4X to 100X (for wide field observations) 10X-100X (for super wide-field observations)	2X to 100X (for wide to super widefield observations)	10X to 100X (for wide to super widefield observations)	

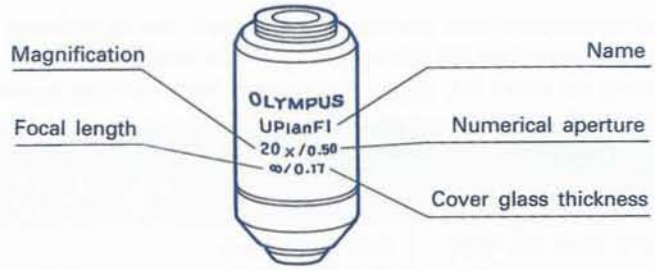

# 7 OPTICAL CHARACTERISTICS



Optical character  Objectives	Mag.	N.A.	W.D. (mm)	Cover glass thickness	Resolution ( $\mu\text{m}$ )	Eyepiece						Remarks
						WH10X (FN22)			WH15X (FN14)			
						Total mag.	Depth of focus ( $\mu\text{m}$ )	Field of view	Total mag.	Depth of focus ( $\mu\text{m}$ )	Field of view	
Ach/Ach-P Achromat/ Achromat for polarized light (FN22)	10X	0.25	6.1	—	1.34	100X	28.0	2.2	150X	20.9	1.4	
	20X	0.40	3.0	—	0.84	200X	6.09	1.1	300X	4.64	0.7	
	40X	0.65	0.45	0.17	0.52	400X	3.04	0.55	600X	2.35	0.35	
	60X	0.80	0.15	0.17	0.42	600X	1.76	0.37	900X	1.39	0.23	
	100XO	1.25	0.13	—	0.27	1000X	0.69	0.22	1500X	0.55	0.14	
*100XOI (Ach only)	100XOI	0.6-1.25	0.13	—	0.27	1000X	0.69	0.22	1500X	0.55	0.14	Iris
Plan Plan Achromat  (FN22)	4X	0.10	22	—	3.36	40X	175	5.5	60X	85.8	3.5	
	10X	0.25	10.5	—	1.34	100X	28.0	2.2	150X	20.9	1.4	
	20X	0.40	1.2	0.17	0.84	200X	6.09	1.1	300X	4.65	0.7	
	40X	0.65	0.56	0.17	0.52	400X	3.04	0.55	600X	2.35	0.35	
	50XOI	0.50-0.90	0.20	—	0.37	500X	1.75	0.44	750X	1.30	0.28	
100XO	1.25	0.15	—	0.27	1000X	0.69	0.22	1500X	0.55	0.14	Iris	
UPlan FI/ UPlan FI-P Universal Semi Apochromatic/ Polarized light Universal Plan Semi Apochromatic (FN26.5)	4X	0.13	17.0	—	2.58	40X	127	5.5	60X	92.9	3.5	
	10X	0.30	10.0	—	1.12	100X	22.4	2.2	150X	16.5	1.4	
	20X	0.50	1.6	0.17	0.67	200X	7.00	1.1	300X	5.22	0.7	
	40X	0.75	0.51	0.17	0.45	400X	2.52	0.55	600X	1.93	0.35	
	100XO	1.30	0.10	0.17	0.26	1000X	0.66	0.22	1500X	0.52	0.14	
100XOI	0.60-1.30	0.10	0.17	0.26	1000X	0.66	0.22	1500X	0.52	0.14	Iris	
UPlan Apo Universal  (FN26.5)	4X	0.16	13.0	—	2.1	40X	99.5	5.5	60X	71.7	3.5	
	10X	0.40	3.1	0.17	0.84	100X	15.9	2.2	150X	11.5	1.4	
	20X	0.70	0.65	0.17	0.48	200X	4.65	1.1	300X	3.39	0.7	
	40X	0.85	0.2	0.11-0.23	0.39	400X	2.14	0.55	600X	1.62	0.35	
	40XOI	0.5-1.00	0.12	—	0.34	400X	1.70	0.55	600X	1.30	0.35	
100XOI	0.5-1.35	0.10	0.17	0.25	1000X	0.62	0.22	1500X	0.49	0.14	Collar Iris Iris	
Plan Apo  (FN26.5)	1.25X	0.04	5.1	—	8.38	12.5X	872	17.6	18.75X	639	11.2	
	2X	0.08	6.0	—	4.19	20X	398	11.0	30X	287	7.0	
	40X	0.95	0.14	0.11-0.23	0.35	400X	1.86	0.55	600X	1.40	0.35	
	60XO	1.40	0.10	0.17	0.24	600X	0.85	0.37	900X	0.64	0.23	
	100XO	1.40	0.10	0.17	0.24	1000X	0.59	0.22	1500X	0.47	0.14	
No Cover Universal Plan Semi Apochromatic UMPlan FI (FN26.5)	40X	0.75	0.63	0	0.45	400X	1.66	0.55	600X	1.27	0.35	
No Cover Plan Apochromatic MPlan Apo (FN26.5)	100XO	1.40	0.10	0	0.24	1000X	0.59	0.22	1500X	0.47	0.14	

# 8 TROUBLESHOOTING GUIDE

Under certain conditions, performance of this unit may be adversely affected by factors other than defects. If problems occur, please review the following list and take remedial action as appropriate. If you cannot solve the problem after checking the entire list, please contact your local Olympus representative for assistance.

Problem	Cause	Remedy	Page
<b>1. Optical System</b>			
a) Lamp does not light.	Bulb burned out.	Replace bulb.	3
	Fuse burned out.	Replace fuse.	6
b) Lamp lights, but field of view remains dark.	Field iris diaphragm is not open wide enough.	Open the field iris diaphragm.	18
	Condenser is too low.	Adjust the condenser position.	18
	Light path selector knob is set to the  position.	Move the knob to the  or  position.	17
c) Field of view is obscured, or field of view is not evenly illuminated.	Light path selector knob is in the middle position.	Set the knob according to the observation method.	17
	The revolving nosepiece is not correctly engaged.	Make sure that the objective clicks properly into place.	9
	The revolving nosepiece is not properly mounted.	Press it in as far as it will go.	10
	You are using an objective that falls outside of the condenser's illumination range.	Use a condenser that matches the objective.	19
	The condenser is not properly centered.	Center the condenser.	18
	The field iris diaphragm is stopped down too far.	Open the field iris diaphragm.	18
	The halogen bulb is not mounted properly.	Push the pins of the halogen bulb into the holes.	3
d) Dirt or dust is visible in the field of view.	Dirt on the light exit glasses	Clean thoroughly.	—
	Dirt on the top surface of the condenser		
	Dirt/dust on the specimen		
	Dirt/dust on the eyepiece		
e) The image is too contrasty and dark.	The condenser is lowered too far.	Adjust the condenser position.	18
	The aperture iris diaphragm is stopped down too far.	Open the aperture iris diaphragm.	19
f) Visibility is poor. • Image is not sharp. • Contrast is poor. • Details are indistinct.	You are using an objective that is not made for the UIS series.	Use an objective made for the UIS series.	—
	The revolving nosepiece is not positioned properly.	Push the nosepiece slider firmly until it comes up against the stop.	10
	The objective is not properly positioned in the light path.	Make sure that the object clicks properly into place.	9
	The correction collar on the correction collar equipped objective is not adjusted.	While focusing, turn the correction collar to find the best position.	—
	The tip of the objective is dirty.	Clean the objective.	—
	Immersion oil is not being used with an oil immersion lens.	Use oil.	21
	The immersion oil contains bubbles.	Remove the bubbles.	21

Problem	Cause	Remedy	Page
f) Visibility is poor. • Image is not sharp. • Contrast is poor. • Details are indistinct.	You are not using the specified immersion oil.	Use the oil provided.	21
	Specimen is dirty.	Clean.	—
	Condenser is dirty.		
	Inappropriate slide or cover glass thickness.	Change to glass of appropriate thickness.	14
g) Part of the image is blurred.	The revolving nosepiece is not properly mounted.	Press the slider in firmly until it comes up against the stop.	10
	The objective is not properly positioned in the light path.	Make sure that the objective clicks properly into place.	9
	The specimen is not properly mounted on the stage.	Put the specimen properly on top of the stage and secure it properly with the specimen clamp.	14
h) The image appears to waver.	The revolving nosepiece is not properly mounted.	Press the slider in firmly until it comes up against the stop.	10
	The objective is not properly positioned in the light path.	Make sure that the objective clicks properly into place.	9
	The condenser is not properly centered.	Center the condenser.	18
i) The field of view becomes only slightly brighter when the voltage is raised.	The condenser is not properly centered.	Center the condenser.	18
	The condenser is lowered too far.	Adjust the condenser position.	18
<b>2. Electrical System</b>			
a) The bulb intermittently lights and goes out.	The bulb is nearly burned out.	Replace the bulb.	3
	A connector is not properly connected.	Check all connections.	—
b) The bulb burns out almost immediately.	You are using the wrong type of bulb.	Use a bulb of the rated type.	3
c) Light intensity does not change when you move the light intensity lever.	The light preset button is set ON.	Press the button to OFF.	11
d) The voltage indicator LEDs do not light, or the bulb does not light.	The voltage selector switch is set to the wrong position.	Set the switch to the position matching to the local line voltage (100 – 120V or 220 – 240V).	6
e) The voltage indicator LEDs all light, and are not affected by the light intensity lever.	The halogen bulb is not installed.	Install the bulb.	3
	The bulb is burned out.	Replace the bulb.	3
	The lamp housing output connector is disconnected.	Properly connect the lamp housing output connector.	3, 4
<b>3. Coarse/Fine Adjustment</b>			
a) The coarse adjustment knob is hard to turn.	The tension adjustment ring is over-tightened.	Loose the ring.	20
	You are trying to raise the stage with the coarse adjustment knob even though the coarse adjustment stopper is locked.	Unlock the stopper.	20
b) The stage goes down by itself, or focus is lost in the course of observation.	The tension adjustment ring is too loose.	Tighten the ring.	20

Problem	Cause	Remedy	Page
c) The image is not focused.	When adjusting the stage height, you forgot to reinstall the upper stopper screw.	Reinstall the upper stopper screw.	15
d) Coarse adjustment will not go all the way up.	The coarse adjustment stopper is keeping the stage down.	Unlock the stopper.	20
e) Coarse adjustment will not go all the way down.	The condenser ring is too low.	Raise the condenser ring.	4
f) The objective bumps into the specimen before focus is obtained.	The specimen is mounted upside-down.	Mount the specimen correctly.	—
<b>4. Observation Tube</b>			
a) Field of view of one eye does not match that of the other.	The interpupillary distance is incorrect.	Adjust the interpupillary distance.	16
	The diopter is not correctly adjusted.	Adjust the diopter.	16
	Different eyepieces are used on the left and right.	Change one eyepiece to match the other so that both sides are the same.	—
	The optical axes are not parallel.	Upon looking into the eyepieces, try looking at the overall field before concentrating on the specimen range. You may also find it helpful to look up and into the distance for a moment before looking back into the microscope.	—
<b>5. Stage</b>			
a) The image moves remarkably when you touch the stage.	The stage is not properly clamped.	Clamp the stage.	4
b) Specimen stops midway on the X axis traverse.	The specimen is not correctly positioned.	Set the specimen correctly.	14
c) The X and Y axes knobs are too tight, or too loose.	Is X or Y axis tension too high or too low?	Adjust the tension.	14

#### When Requesting Repair

If checking all of the above points does not correct the problem, please contact the dealer from whom you purchased the microscope for assistance. When doing so, please provide the following information.

- Model name
- Manufacture number
- Problem



# **OLYMPUS**

## **OLYMPUS OPTICAL CO., LTD.**

43-2, Hatagaya 2-chome, Shibuya-ku, Tokyo, Japan

## **OLYMPUS OPTICAL CO., (EUROPA) GMBH.**

(Premises/Goods delivery) Wendenstrasse 14-16, 20097 Hamburg, Germany.  
(Letters) Postfach 10 49 08, 20034 Hamburg, Germany.

## **OLYMPUS AMERICA INC.**

4 Nevada Drive, Lake Success, N.Y. 11042-1179, U.S.A.

## **OLYMPUS OPTICAL CO. (U.K.) LTD.**

2-8 Honduras Street, London EC1YOTX, United Kingdom

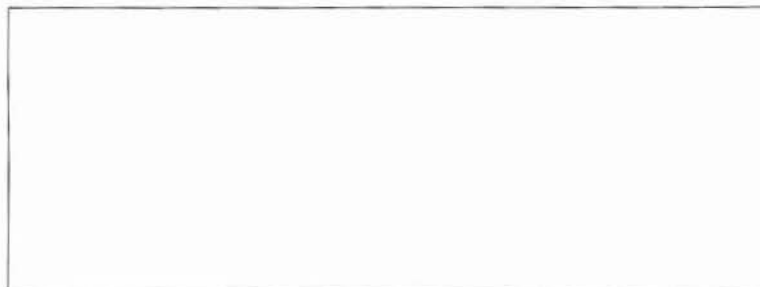

The design of the product is under constant review and while every effort is made to keep this manual up to date, the right is reserved to change specifications and equipment at any time without prior notice.

This publication is printed on recycled paper.

Printed in Japan 9312 M 10